

# FORWARD

*Congratulations on the acquisition of your new Catalina 27. All Catalina yachts are designed and built with care using quality materials to assure you years of sailing enjoyment with a minimum of upkeep and maintenance.*

*Before attempting maintenance or operation of your Catalina 27, please read the Catalina Yachts Limited Warranty booklet and fill out the enclosed warranty registration card.*

*The registration card enables Catalina to inform you of developments and modifications to enhance the performance or comfort of your yacht. It is also important to be able to contact owners to comply with Coast Guard notification requirements.*

*The launching and rigging of the Catalina 27 should be handled by experienced boat yard personnel under the direction of your authorized dealer. After the boat is launched, the dealer will complete the last stages of rigging and mast tuning.*

*The index page lists the contents of this manual. Warrantees and information regarding installed optional equipment have been included when available and applicable.*

*Maintaining your yacht properly can become a satisfying part of your sailing activities. A regular inspection is the best preventive maintenance. It will help keep your boat safe and in good condition while in use, and insure peace of mind when the boat is left unattended.*

*Take good care of your boat and take the time to learn and practice good seamanship.*



# PREFACE

*This manual is intended and supplied to help owners of Catalina 27's understand their boats and answer common questions about maintenance and systems design specific to the Catalina 27.*

*This manual is not intended to provide sailing instructions. It is assumed operator will consult books written for that purpose, or take sailing lessons or courses to gain the knowledge necessary for the safe operation of his vessel.*

*The systems descriptions and illustrations in this manual apply to boats built at the time of publication. Our policy of constant improvement necessitates that changes have been made to the Catalina 27 since its introduction. Therefore, because of these changes, illustrations and descriptions may not apply to boats built before the time of publication.*

*Owners of earlier hulls, who have questions not answered herein should consult with their local Catalina dealer, or write to Catalina Yachts. Please include your hull number in all correspondence.*

*The maintenance check lists contained within this manual are intended as guidelines for boats in normal service under typical conditions.*

*Climate and use will vary and may require additional or specific maintenance. Consult with your local boat yard or Catalina dealer for special maintenance and precautions recommended for your purposes and climate.*

*Caution: The aluminum and other metal parts conduct electricity. Coming in contact with or near an electrical power line or lightning can cause severe injury or death. Stay away from overhead electrical power lines when sailing and/or launching the boat.*





1.0	<u>INTRODUCTION</u>	
1.1	REFERENCE DATA SHEET	6
2.0	<u>COMMISSIONING CHECK LIST</u>	
2.1	PRE-LAUNCH CHECK	7
2.2	IN WATER CHECK	7
2.2.1	ELECTRICAL	8
2.2.2	PLUMBING	8
2.2.3	RIGGING AND HARDWARE	8
2.2.4	ENGINE (OPTIONAL INBOARD DIESEL)	8-9
2.3	SAILING CHECK LIST	9
2.3.1	FINAL CHECK	9
3.0	<u>MAINTENANCE GUIDE</u>	
3.1	PRE-USE MAINTENANCE AND INSPECTION	10
3.2	MONTHLY MAINTENANCE	10
3.3	SEASONAL MAINTENANCE	11
3.4	FIBERGLASS MAINTENANCE AND REPAIR	12
3.4.1	TOUCH UP AND SURFACE REPAIR INSTRUCTIONS	13-14
3.5	TEAK MAINTENANCE	15
3.6	SPAR AND RIGGING MAINTENANCE	15-17
3.7	SAIL MAINTENANCE	17-18
3.8	INTERIOR CUSHIONS, FABRIC COVER	19
3.8.1	CURTAINS	19
4.0	<u>YACHT SYSTEMS</u>	
4.1	RIGGING	19
4.1.1	TUNING THE MAST	19
4.1.2	RIGGING WIRE LENGTH CHECK LIST	20
4.1.3	SAIL PLAN (FOLD OUT)	21-22
4.1.4	SPREADER BRACKET ASSEMBLY	23
4.1.5	INTERNAL HALYARD MASTHEAD ASSEMBLY	24
4.1.6	MAINSAIL REEFING	25
4.1.7	MAINSAIL REEFING ASSEMBLY	26
4.1.8	ADJUSTABLE OUTHAUL AND GOOSENECK ASSEMBLY	27
4.1.9	MAINSHEET RIGGING	28
4.1.10	TRAVELER ASSEMBLY	29
4.1.11	HALYARD ARRANGEMENT	30
4.1.12	BOOM VANG ARRANGEMENT	31
4.1.13	BACKSTAY ADJUSTER SYSTEM	32
4.1.14	TOPPING LIFT ASSEMBLY	33
4.2	ELECTRICAL	34
4.2.1	BATTERIES	34
4.2.2	110 VOLT SYSTEM	35
4.2.3	110 VOLT, SHORE POWER SCHEMATIC	35
4.2.4	WIRING SCHEMATIC	36

4.3	PLUMBING	37
4.3.1	PLUMBING SCHEMATIC	37
4.3.2	MANUAL BILGE PUMP	38
4.3.3	ELECTRIC BILGE PUMP	38
4.3.4	THROUGH HULL LOCATIONS	38
4.3.5	HOT AND COLD PRESSURE WATER SYSTEM	39
4.3.6	SEACOCKS	40
4.3.7	MARINE TOILET OPERATION	40-41
4.3.8	MACERATOR PUMP TROUBLESHOOTING	41
4.3.9	SANITATION SYSTEM PLUMBING	42
4.4	AUXILIARY POWER	43
4.4.1	GENERAL ENGINE INFORMATION	43
4.4.2	OUTBOARD RECOMMENDATIONS	43
4.4.3	SHAFT PACKING GLAND (STUFFING BOX)	44
4.4.4	SHAFT ALIGNMENT	44-45
4.4.5	SHAFT ALIGNMENT ILLUSTRATION	46
4.4.6	FUELING	47-48
4.4.7	FUEL SANITATION	48
4.4.8	FUEL SYSTEM ILLUSTRATION	49
4.4.9	ENGINE EXHAUST SYSTEM ILLUSTRATION	50
4.4.10	EXHAUST SYSTEM MAINTENANCE	51-52
4.5	STEERING	52
4.5.1	EMERGENCY TILLER	52
4.6	DECK HARDWARE	53
4.6.1	DECK HARWARE ARRANGEMENT PLAN	53
4.7	ACCOMMODATION	54
4.7.1	CABIN ARRANGEMENT	54
4.7.2	GALLEY STOVE	55
5.0	<u>DECOMMISSIONING</u>	
5.1	DIMENSIONS FOR LIFTING PROCEDURE	56
5.2	LAYING UP	57
5.3	BEFORE HAULING	57
5.4	AFTER HAULING	57-58
5.4.1	GENERAL NOTES	59
6.0	<u>OWNER-USER RESPONSIBILITY</u>	
6.1	GENERAL SAFETY TIPS	60
6.2	REQUIRED SAFETY EQUIPMENT	61
6.3	SUGGESTED SAFETY EQUIPMENT	61
6.4	SAFETY PACKAGE, FACTORY OPTION	62
6.5	ANCHORS, ANCHORING AND MOORING	62
6.6	LIGHTNING PRECAUTIONS	63-64

EQUIPMENT MANUFACTURER'S ENCLOSURES

1. PEDESTAL STEERING
2. HEADSAIL REEFING
3. PRESSURE WATER PUMP, MACERATOR PUMP
4. MARINE TOILET
5. COMPASS
6. BATTERIES
7. WINCH MANUALS
8. ENGINE MANUALS
9. KNOT METER
10. GALLEY STOVE
11. FUEL FILTERS
12. BILGE PUMP
13. GALLEY FOOT PUMP
14. RUNNING LIGHTS
15. REFRIGERATION

NOTE:

EQUIPMENT MANUFACTURERS LITERATURE WILL BE INCLUDED WITH THIS MANUAL ONLY WHEN AVAILABLE AND APPLICABLE TO THE HULL NUMBER FOR WHICH THE MANUAL IS INTENDED. THIS INFORMATION HAS BEEN PREPARED AND SUPPLIED BY THE EQUIPMENT MANUFACTURER AND MAY ILLUSTRATE INSTALLATIONS OR APPLICATIONS WHICH VARY FROM CATALINA STANDARD PRACTICE. CATALINA IS NOT RESPONSIBLE FOR THE ACCURACY OF INFORMATION SUPPLIED BY EQUIPMENT MANUFACTURERS.



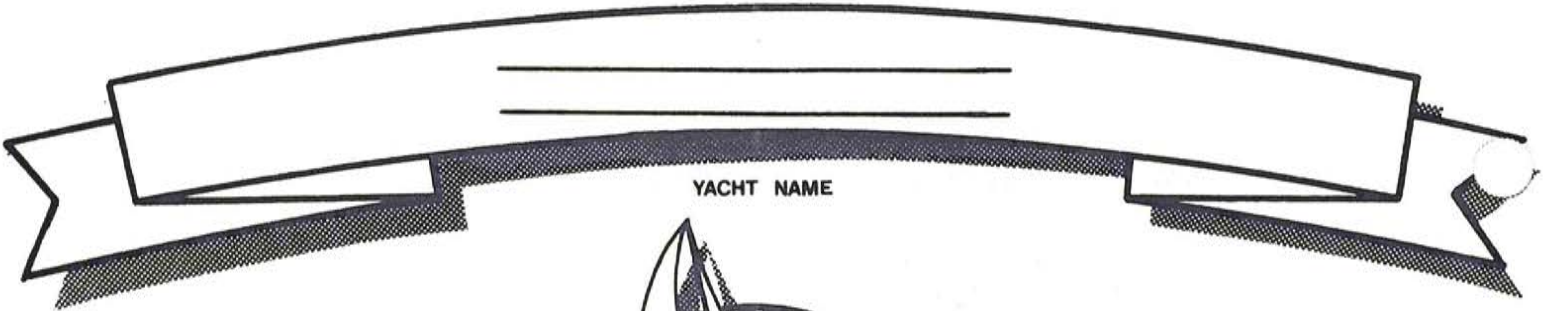

YACHT NAME



OWNER'S NAME	OWNER'S ADDRESS
REGISTRATION OR DOCUMENTATION	HULL NUMBER
PORT OF CALL	DATE OF COMMISSIONING

<p>LENGTH, OVER ALL</p> <p>STANDARD ..... 26'-10"</p>	<p>FUEL CAPACITY..... 20 GAL</p>
<p>MAST HEIGHT ABOVE</p> <p>STANDARD ..... 38.3 FT</p> <p>TALL RIG ..... 39.8 FT</p>	<p>DISPLACEMENT</p> <p>STANDARD ..... 6850 lbs</p> <p>SHOAL ..... 6750 lbs</p>
<p>DRAFT</p> <p>STANDARD ..... 4'-0"</p> <p>SHOAL ..... 3'-5"</p>	<p>BALLAST</p> <p>STANDARD ..... 2700 lbs</p> <p>SHOAL ..... 2600 lbs</p>
<p>BEAM ..... 8'-10"</p>	<p>HEIGHT ON CRADLE ..... 11'-0"</p>
<p>LENGTH, WATERLINE ..... 21'-9"</p>	<p>ENGINE SERIAL NUMBER</p>
<p>WASTE TANK, CAPACITY ..... 21 GAL</p>	<p>SAIL NUMBER</p>
<p>FRESH WATER, CAPACITY ..... 18 GAL</p>	<p>RADIO TELEPHONE NUMBER</p>



## 2.0 COMMISSIONING CHECK LIST

### 2.1 PRE-LAUNCH CHECK:

1. \_\_\_ SHAFT TURNS FREELY BY HAND, ZINC COLLAR INSTALLED, IF REQUIRED
2. \_\_\_ CHECK INTAKE HOSES AND CLAMPS
3. \_\_\_ CHECK ALL THROUGH HULL FITTINGS
4. \_\_\_ DRAIN PLUGS TIGHT, \_\_\_ ENGINE, MUFFLER AND EXHAUST LINE
5. \_\_\_ BOTTOM CLEAN, PAINT OK
6. \_\_\_ HULL SIDES CLEAN, GEL COAT OK
7. \_\_\_ DECKS CLEAN
8. \_\_\_ TEAK CLEAN AND OILED
9. \_\_\_ INTERIOR FINISHED, OILED, CLEAN
10. \_\_\_ CUSHIONS, CARPETING, CURTAINS -- CLEAN AND IN PLACE
11. \_\_\_ TABLE CONVERTS TO BERTH OK; DINETTE, TRADITIONAL TABLE STOWS OK
12. \_\_\_ HATCH LIDS PRESENT AND FIT OK
13. \_\_\_ LIFELINES AND PULPITS RIGGED AND OK
14. \_\_\_ SPREADERS TAPED AND DRILLED AT BASE END; UPPER SHROUD WIRED TO TIP END AND TAPED
15. \_\_\_ STANDING RIGGING PINNED TO MAST
16. \_\_\_ RIGGING LENGTHS VERIFIED WITH CHECK LIST IN KIT
17. \_\_\_ MAST AND BOOM INSPECTED; COTTER PINS, SHEAVES, TANGS, SPREADERS OK
18. \_\_\_ MAST LIGHTS CHECKED BEFORE MAST STEPPED
19. \_\_\_ CHECK OVERHEAD FOR ELECTRICAL WIRES WHICH MAY INTERFERE WITH THE SPACE REQUIRED TO RAISE THE MAST TO ITS FULL UPRIGHT POSITION. IF THERE ARE WIRES OF ANY KIND, ANYWHERE NEAR THE BOAT, DO NOT RAISE THE MAST. MOVE BOAT TO ANOTHER LOCATION, AWAY FROM ANY WIRES. CONTACT WITH WIRES CAN BE FATAL.

### 2.2 IN WATER CHECK:

#### 2.2.1 ELECTRICAL

1. \_\_\_ ELECTRICAL EQUIPMENT OPERATIONAL:  
\_\_\_ RUNNING \_\_\_ CABIN \_\_\_ BOW \_\_\_ ANCHOR \_\_\_ DECKLIGHT  
\_\_\_ PRESSURE WATER \_\_\_ MACERATOR PUMP \_\_\_ BILGE PUMP
2. \_\_\_ SHORE POWER OUTLET, REVERSE POLARITY INDICATOR, NOT ON
3. \_\_\_ CHECK BATTERY SWITCH #1 \_\_\_ OK, #2 \_\_\_ OK
4. \_\_\_ CHECK BATTERY FLUID LEVEL
5. \_\_\_ CHECK BATTERY TERMINAL FOR TIGHTNESS

2.0 COMMISSIONING CHECK LIST CONT.

2.2.2 PLUMBING

1. \_\_\_ NO LEAKS AT THROUGH HULL FITTINGS WITH SEACOCKS OPEN
2. \_\_\_ FILL ALL WATER TANKS
3. \_\_\_ CHECK ALL WATER TANK CONNECTIONS FOR LEAKS
4. \_\_\_ TEST ALL FAUCETS AND FOOT PUMPS FOR LEAKS
5. \_\_\_ CHECK FOR LEAKS AT SINK DRAIN, SINK DRAINS OK
6. \_\_\_ PUT WATER IN ICEBOX AND CHECK FOR PROPER DRAINAGE
7. \_\_\_ CHECK MANUAL BILGE PUMP OPERATION, HANDLE PRESENT
8. \_\_\_ CHECK HEAD BY FLUSHING AND PUMPING
9. \_\_\_ CHECK SHOWER SUMP DRAIN LINE
10. \_\_\_ CHECK HOLDING TANK, PUMP VENT AND FITTING
11. \_\_\_ CHECK HEAD AND PUMP HANDLE FOR LEAKS
12. \_\_\_ MAIN HATCH NO LEAKS, SLIDES FREELY; HATCH BOARDS FIT OK
13. \_\_\_ CABIN WINDOWS HOSE TESTED FOR LEAKS
14. \_\_\_ ANCHOR LOCKER DRAIN OK
15. \_\_\_ STOVE OPERATES OK; HOSES, FITTINGS AND TANK OK

2.2.3 RIGGING AND HARDWARE

1. \_\_\_ MAST STEPPED
2. \_\_\_ PIN, TAPE AND TUNE STANDING RIGGING
3. \_\_\_ BACKSTAY ADJUSTER, WHISKER POLE, SPINNAKER GEAR, BOOM VANG
4. \_\_\_ BLOCKS, CARS, CLEATS RIGGED OK
5. \_\_\_ TEST ALL WINCHES, WINCH HANDLES PRESENT

2.2.4 ENGINE

1. \_\_\_ NO LEAKS IN SHAFT, RUDDER, STUFFING BOX OR SHAFT LOG
2. \_\_\_ SHAFT DIMPLED FOR SET BOLTS AT COUPLING; BOLTS WIRED; COUPLING SECURED
3. \_\_\_ WITH FUEL TANKS FULL, NO LEAKS AT FILL PIPES, OVERFLOW VENT OR ANY FUEL LINE CONNECTIONS
4. \_\_\_ WITH COUPLING DISCONNECTED FROM ENGINE; ENGINE AND SHAFT ALIGNMENT OK; RE-CHECK ALIGNMENT AFTER RIGGING TUNED
5. \_\_\_ TRANSMISSION OIL LEVEL OK
6. \_\_\_ CRANK CASE OIL LEVEL OK
7. \_\_\_ FUEL VALVES OPEN; BLEED AND PRIME LINES
8. \_\_\_ CHECK THAT SHAFT IS COUPLED AND ALIGNED TO .003 MAXIMUM TOLERANCE

2.0 COMMISSIONING CHECK LIST CONT.

2.2.4 ENGINE CONT.

9. \_\_\_ ENGINE WIRING OK, CONNECTIONS TIGHT, ALL PANEL GAUGES OK
10. \_\_\_ THROTTLE CONTROL CABLE TRAVEL AND BRACKETS OK
11. \_\_\_ CLUTCH CONTROL CABLE TRAVEL AND BRACKETS OK
12. \_\_\_ START ENGINE
13. \_\_\_ EXHAUST WATER FLOW OK
14. \_\_\_ NO LEAKS IN FUEL LINES AT FITTING, FUEL FILTER, FUEL PUMP
15. \_\_\_ NO ENGINE OR OIL LEAKS
16. \_\_\_ IDLING SPEED SET \_\_\_ RPM'S
17. \_\_\_ CHECK CHOKE OPERATION, CHECK SHUTOFF CABLE
18. \_\_\_ CHECK FORWARD AND REVERSE SHIFTING
19. \_\_\_ CHECK ENGINE INSTRUMENTS FOR OPERATION, TACHOMETER FOR CALIBRATION
20. \_\_\_ RUN IN GEAR FOR TEN (10) MINUTES
21. \_\_\_ RE-CHECK PACKING GLAND AFTER ENGINE STOPS
22. \_\_\_ BILGE BLOWER AND VENT SYSTEM OK
23. \_\_\_ EXHAUST SYSTEM CHECK FOR LEAKS, INSULATION IN PLACE
24. \_\_\_ ENGINE SHUT OFF CABLE, OK
25. \_\_\_ ENGINE PANEL ALARM SYSTEM, OK

2.3 SAILING CHECK LIST

1. \_\_\_ TILLER MOVES FREELY, 30 DEGREES MINIMUM, AT EACH SIDE OF CENTER LINE
2. \_\_\_ PEDESTAL STEERING OPERATION, OK
3. \_\_\_ SAILS AND HALYARDS OK
4. \_\_\_ BOAT PERFORMANCE UNDER POWER AND SAIL OK
5. \_\_\_ COMPASS CALIBRATED

2.3.1 FINAL CHECK

1. \_\_\_ ALL ACCESSORY EQUIPMENT OPERATES OK
2. \_\_\_ ALL BOAT, ENGINE AND ACCESSORY LITERATURE AND/OR MANUALS ABOARD
3. \_\_\_ WARRANTY CARDS COMPLETED AND MAILED, OWNER REGISTRATION CARD ATTACHED, OWNER INFORMED OF WARRANTY RESPONSIBILITIES
4. \_\_\_ ENGINE WARRANTY CARD COMPLETED AND MAILED



### 3.0 MAINTENANCE GUIDE

#### 3.1 PRE-USE MAINTENANCE AND INSPECTION:

##### RIGGING

1. INSPECT TURNBUCKLES -- TIGHTEN IF NECESSARY. TUNE RIGGING PER INSTRUCTIONS
2. INSPECT CLEVIS PINS AND COTTER PINS
3. VISUALLY INSPECT SPREADER TIPS AND OTHER AREAS WHERE SAILS MAY CHAFE DURING SAILING; REPLACE TAPE AS NECESSARY
4. HALYARDS FREE AND NOT TANGLED
5. INSPECT MAST HARDWARE ATTACHMENT BOLTS; TIGHTEN AS REQUIRED

##### HULL AND DECK INSPECTION

1. RUDDER MOVES FREELY, PEDESTAL STEERING OK, RUDDER POST PACKING GLAND OK
2. BILGES AND COMPARTMENTS ARE DRY
3. THROUGH HULL VALVES, HOSES AND CLAMPS OK
4. CHECK RUNNING LIGHTS

##### ENGINE

1. CHECK ENGINE OIL AND FUEL LEVELS
2. PACKING GLAND OK, COOLING WATER INTAKE VALVE OPENS AND CLOSES OK
3. THROTTLE SHIFT OK
4. BLOWER SYSTEM FUNCTIONAL
5. CHECK BILGE AREAS FOR FUEL BEFORE STARTING ENGINE

#### 3.2 MONTHLY MAINTENANCE:

##### RIGGING

1. INSPECT CHAIN PLATES, FASTENINGS AND BOLTS, TIGHTEN AS NECESSARY
2. INSPECT BLOCKS, SHACKLES AND COTTER PINS
3. CHECK RIGGING TUNE, RIGGING WIRE CONDITION
4. CHECK TURNBUCKLES AND LOCKING PINS

##### HULL AND DECK

1. CHECK COCKPIT DRAINS, CLEAR DEBRIS
2. INSPECT THROUGH HULL VALVES, OPEN AND CLOSE FREELY
3. WINCHES TURN FREELY, LUBRICATE AS PER MANUFACTURER'S RECOMMENDATIONS
4. CLEAN AND OIL EXTERIOR TEAK AS NECESSARY
5. CLEAN AND WAX GEL COAT SURFACES AS NECESSARY

##### ENGINE

1. CHECK OIL AND FLUID LEVELS
2. BATTERY: CHECK FLUID LEVELS AND TIE DOWNS
3. TIGHTEN ALL BOLTS AND NUTS TO PROPER TORQUE
4. CHECK FUEL TANK FITTINGS AND HOSE CLAMPS
5. DISASSEMBLE AND INSPECT COOLING SYSTEM ANTI-SIPHON



3.0 MAINTENANCE GUIDE CONT.

3.3 SEASONAL MAINTENANCE:

RIGGING

1. MAST HEAD PINS AND SHEAVES TURN FREELY
2. HALYARDS NOT CHAFED, SHACKLES OK
3. SPREADER TIPS AND BASES; MAST FITTINGS
4. ALL SHROUD TERMINATIONS AND SWAGED FITTINGS NOT CRACKED OR CORRODED
5. GOOSENECK ASSEMBLY AND BOOM ASSEMBLY, OK
6. MAST, BOOM AND SPREADERS CLEANED AND WAXED

HULL, DECK AND CABIN

1. ALL CHAINPLATES AND THROUGH BOLTS ARE TIGHT
2. DISASSEMBLE WINCHES AND LUBRICATE BEARINGS AND PAWLS
3. COAT ELECTRICAL SYSTEM, BATTERY TIE DOWNS AND TERMINAL CONNECTORS TO PREVENT CORROSION
4. DRAIN AND FLUSH FRESH WATER SYSTEM
5. CHECK HEAD AND CHECK VALVE IN TOILET
6. BOTTOM, KEEL AND RUDDER CONDITION OK, LUBRICATE RUDDERPOST AS REQUIRED
7. LIFELINES, STANCHIONS AND PELICAN HOOKS OK, LUBRICATE AND REBED AS REQUIRED

ENGINE

1. CHECK SHAFT ALIGNMENT, REPACK STUFFING BOX IF NECESSARY
2. CLEAN MOTOR THOROUGHLY
3. INSPECT FUEL SYSTEM
4. TUNE ENGINE AS PER MANUFACTURER'S RECOMMENDATIONS
5. EXHAUST SYSTEM, INSULATION IN PLACE, CHECK FOR LEAKS OR DETERIORATION, DISASSEMBLE AS NECESSARY TO DETERMINE CONDITION OF EXHAUST RISER AND ALL FITTINGS
6. DRAIN AQUALIFT MUFFLER

3.0 MAINTENANCE GUIDE CONT.

3.4 FIBERGLASS MAINTENANCE AND REPAIR:

ONE OF THE MAJOR BENEFITS OF A FIBERGLASS BOAT IS THE ELIMINATION OF MAINTENANCE CHORES REQUIRED BY OTHER MATERIALS. YOU HAVE ONLY THREE RELATIVELY EASY MAINTENANCE RULES TO FOLLOW TO KEEP YOUR BOAT LOOKING LIKE NEW:

1. EACH YEAR, CLEAN, BUFF AND WAX THE EXTERIOR OF THE BOAT
2. TOUCH UP AND PATCH SCRATCHES, SCARS AND SMALL BREAKS
3. REPAIR ANY MAJOR BREAKS AS SOON AS POSSIBLE TO AVOID ADDITIONAL DAMAGE TO THE HULL OR DECKS

MOST FIBERGLASS BOATS ARE MANUFACTURED OF TWO "LAYERS" OF MATERIAL, PERMANENTLY BONDED TOGETHER BY A CHEMICAL REACTION. THE OUTSIDE SURFACE IS FORMED BY A COLORED GEL COAT. THIS IS A SPECIAL RESIN MATERIAL CONTAINING CONCENTRATED COLOR. IT PROVIDES A SMOOTH, FINISHED SURFACE.

THE SECOND "LAYER" IS MADE UP OF POLYESTER RESIN REINFORCED WITH LAMINATIONS OF FIBERGLASS MAT, CLOTH AND WOVEN ROVING. BOTH THE GEL COAT AND POLYESTER RESIN ARE "CURED" BY A CHEMICAL CATALYST WHICH CAUSES THEM TO FORM A HARD, STRONG MASS THAT IS HIGHLY RESISTANT TO IMPACT AND DAMAGE.

AFTER SAILING, A GOOD WASH DOWN WITH FRESH WATER AND A MILD DETERGENT WILL KEEP YOUR BOAT SPARKLING FRESH AND CLEAN. THE NON-SKID SURFACES NEED TO BE SCRUBBED WITH DETERGENT. SMOOTH GLASS AREAS MAY BE POLISHED WITH LIQUID WAX OR ANY GOOD FIBERGLASS WAX TO ADD EXTRA LUSTER. IN THE CASE OF OLDER BOATS, WHERE SOME FADING OF THE GEL COAT HAS OCCURRED, THE SURFACE SHOULD BE BUFFED WITH POLISHING COMPOUND AND THEN WAX FINISHED.

WHEN BUFFING THE BOAT TO RESTORE ITS FINISH, CARE SHOULD BE TAKEN NOT TO CUT THROUGH THE GEL COAT SURFACE. THIS IS ESPECIALLY TRUE ON CORNERS AND EDGES OF THE HULL. A POWER BUFFER MAY BE USED, OR THE WORK MAY BE DONE BY HAND, USING A LIGHTLY ABRASIVE RUBBING COMPOUND SUCH AS MIRRO GLAZE NO. 1 FOR POWER BUFFERS, OR DUPONT NO. 7 FOR HAND BUFFING. ANY HIGH QUALITY PASTE WAX MAY BE USED AFTER BUFFING.

NOTE: BOTTOM PAINT PREPARATION:

ALL C-27's BUILT AFTER 2-1-88 HAVE A BLISTER RESISTANT GEL COAT. SPECIAL PRECAUTION MUST BE USED WHEN PREPARING THIS BOTTOM FOR PAINTING. DO NOT SAND OR REDUCE GEL COAT FILM THICKNESS, USE "NO SAND" TYPE PRIMER TO PREPARE THE BOTTOM FOR PAINTING. IMPROPER BOTTOM PREPARATION WILL VOID YOUR CATALINA YACHTS FIVE YEAR GEL COAT LIMITED WARRANTY.

ANTI-FOULING PAINT SHOULD BE APPLIED TO THE BOTTOM OF YOUR CATALINA 27 IF IT IS TO BE MOORED IN EITHER FRESH OR SALT WATER FOR ANY LENGTH OF TIME. THERE ARE MANY BRANDS AVAILABLE. ANTI-FOULING PAINT PREVENTS THE GROWTH OF ALGAE, BARNACLES, AND OTHER FOULING ORGANISMS ON UNDERWATER SURFACES.



### 3.4.1 FIBERGLASS TOUCH UP AND REPAIR

#### Scratches, Shallow Nicks, Gouges, Small Holes (that do not penetrate through the hull)

These repairs are easy because only the surface of the boat is damaged. They fall into two categories: (1) damage to the gel coat colored outer surface, and (2) holes or gouges that are deep enough to penetrate the fiber glass reinforced area of the boat. The repair operations are similar.

For damage to the gel coat surface, you will need a small can of gel coat, of the same color as your boat, and a small amount of catalyst. For deeper holes or gouges (1/8" or more) you will also need some short strands of fiber glass which can be trimmed from fiber glass mat or purchased in the form of "milled fibers." These materials can be purchased from your dealer.

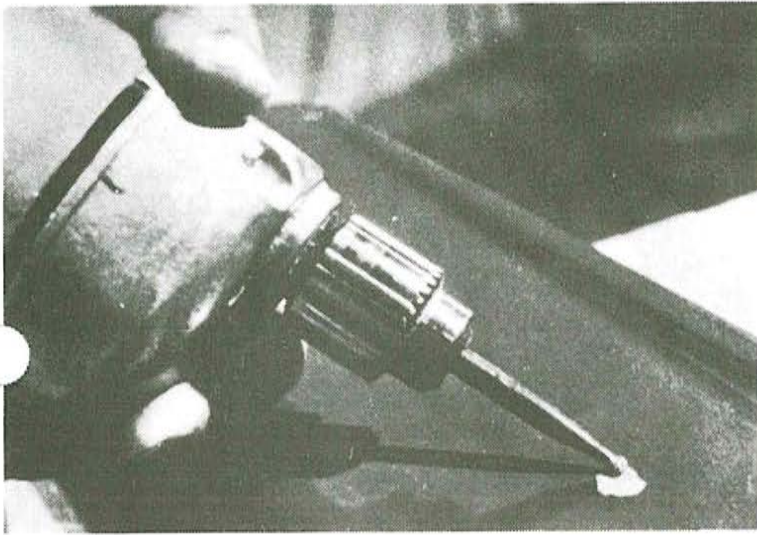

- (1) Be sure the area around the damage is wiped clean and dry. Remove any wax or oil from the inside of the hole or scratch.
- (2) Using a power drill with a burr attachment, roughen the bottom and sides of the damaged area and feather the edge surrounding the scratch or gouge. Do not "undercut" this edge. (If the scratch or hole is shallow and penetrates only the color gel coat, skip to step No. 8.)
- (3) Into a jar lid or on a piece of cardboard, pour a small amount of gel coat . . . just enough to fill the area being worked on. Mix an equal amount of milled fibers with this gel coat, using a putty knife or small flat stick. Then add two drops of catalyst, using an eyedropper for accurate measurement. For a half-dollar-size pile of gel coat, this amount of catalyst will give you 15 to 20 minutes working time before it begins to "gel". Carefully cut the catalyst into the gel coat and mix thoroughly.

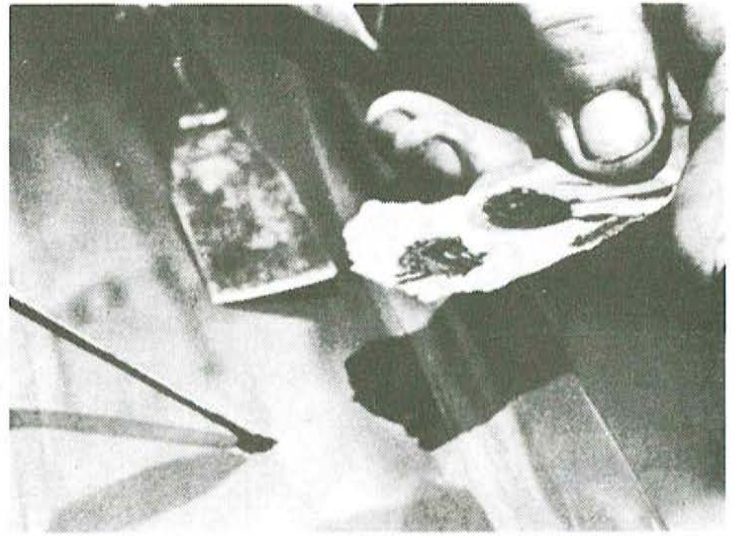

- (4) Work this mixture of gel coat, fibers and catalyst into the damaged area, using the sharp point of a putty knife or knife blade to press it into the bottom of the hole and to puncture any air bubble which may occur. Fill the scratch or hole above the surrounding undamaged area about 1/16".

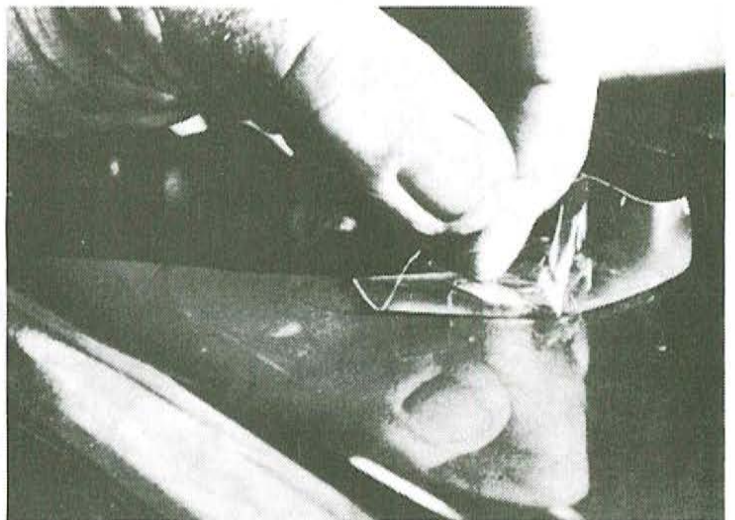
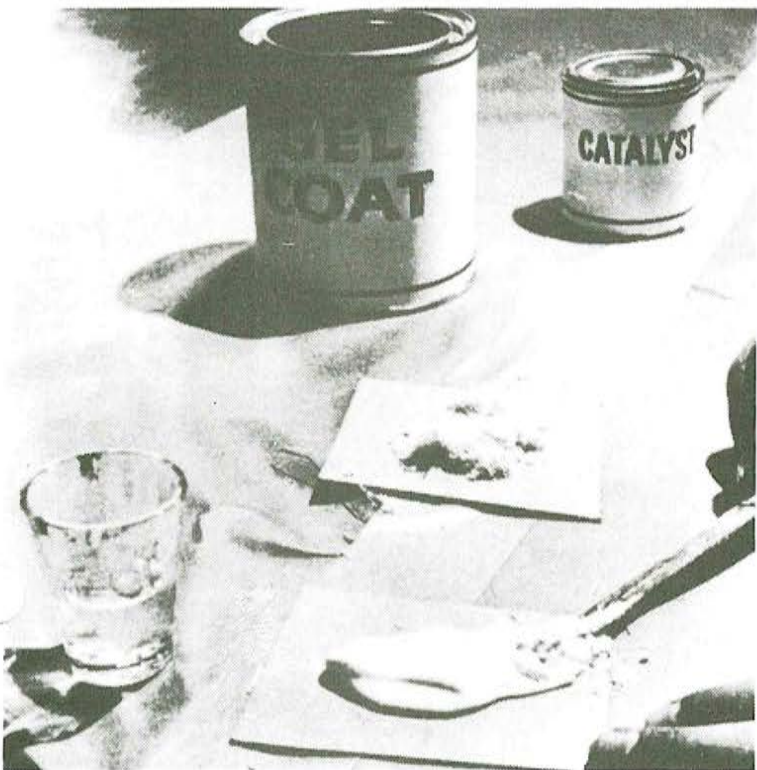

- (5) Lay a piece of cellophane or waxed paper over the repair to cut off the air and start the "cure."



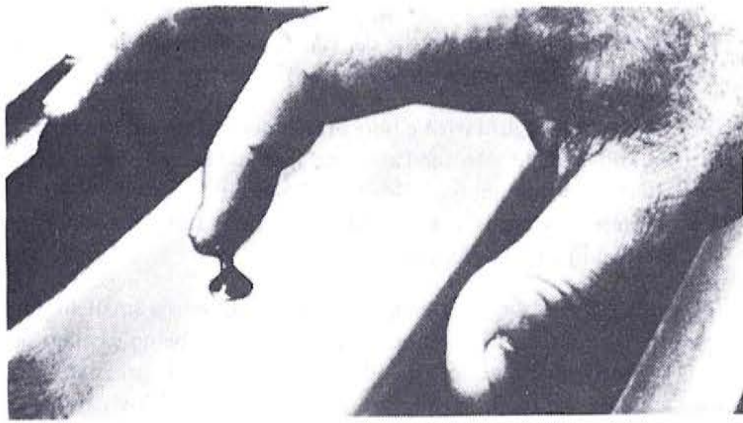

- (6) After 10 or 15 minutes the patch will be partially cured. When it feels rubbery to the touch, remove the cellophane and trim flush with the surface, using a sharp razor blade or knife. Replace the cellophane and allow to cure completely (30 minutes to an hour). The patch will shrink slightly below the surface as it cures.
- (7) Again use the electric drill with burr attachment to rough up the bottom and edges of the hole. Feather hole into surrounding gel coat, do not undercut.

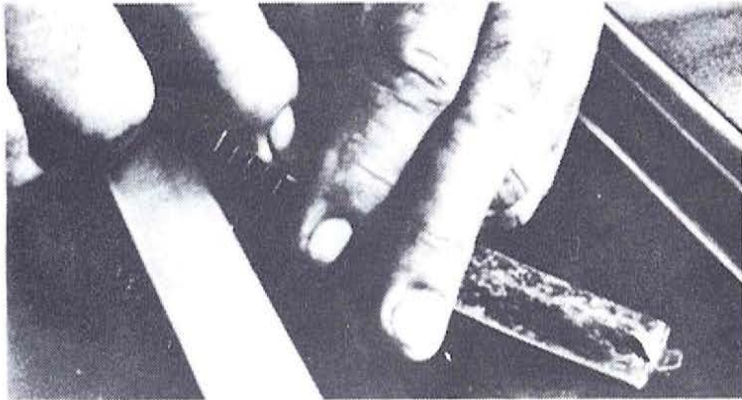

- (8) Pour out a small amount of gel coat into a jar lid or on cardboard. Add a drop or two of catalyst and mix thoroughly, using a cutting motion rather than stirring. Use no fibers.
- (9) Using your finger tip or the tip of a putty knife, fill the hole about 1/16" above the surrounding surface with the gel coat mixture.

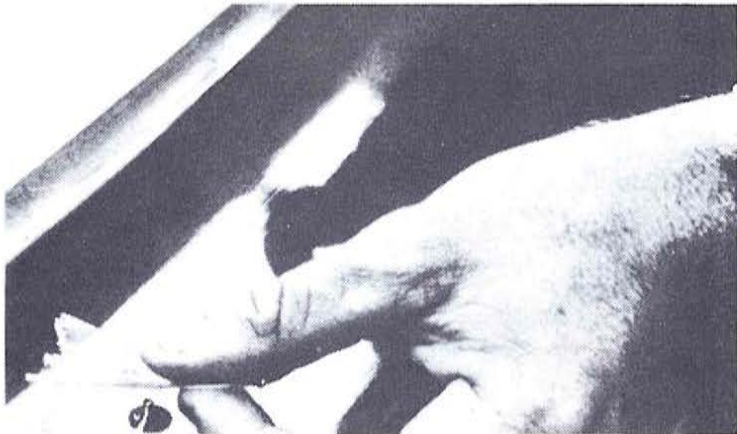

10. Lay a piece of cellophane over the patch to start the curing process. Repeat step 6, trimming patch when partially cured.

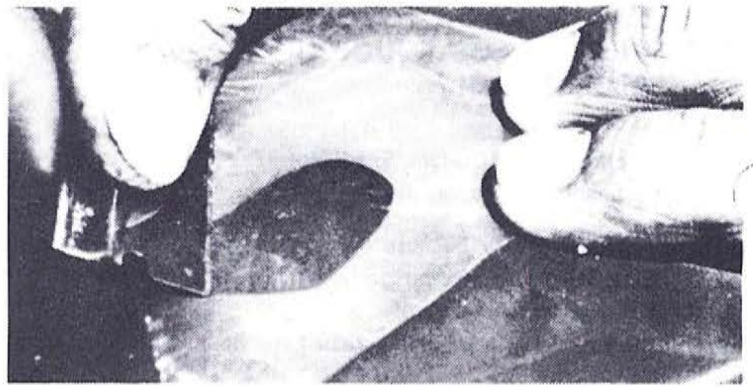

11. Immediately after trimming, place another small amount of gel coat on one edge of the patch and cover with cellophane. Then, using a rubber squeegee or back of the razor blade, squeegee level with area surrounding the patch. Leave cellophane on patch for 1 to 2 hours, or overnight, for a complete cure.



12. USING A SANDING BLOCK, sand the patched area with 600 grit WET sandpaper. Finish by rubbing or buffing with a fine rubbing compound. Some slight color difference may be observed. Weathering will blend touch-up, if properly applied.



### 3.0 MAINTENANCE GUIDE CONT.

#### 3.5 TEAK MAINTENANCE:

EXTERIOR WOOD IS TEAK. TEAK PARTS CAN BE KEPT LOOKING GOOD BY OCCASIONAL CLEANING AND OILING WITH TEAK OIL.

SHOULD THE TEAK BECOME WEATHERED, CLEANING AND BLEACHING WITH A COMMERCIALY AVAILABLE TEAK CLEANER AND BLEACH WILL RESTORE THE COLOR OF THE WOOD. THEN OIL THE WOOD WITH A GOOD GRADE TEAK OIL TO RESTORE THE GOLDEN COLOR OF THE TEAK. DO NOT USE WIRE OR HARD BRISTLE BRUSHES ON THE WOOD, AS THIS WILL REMOVE THE SOFTER WOOD BETWEEN THE ANNUAL RINGS AND LEAVE A ROUGH SURFACE. BADLY DETERIORATED TEAK CAN BE SANDED TO RESTORE A CLEAN SMOOTH SURFACE. FINISH WITH SEVERAL COATS OF TEAK OIL OR VARNISH TO MAINTAIN THE SURFACE FINISH.

#### 3.6 SPAR AND RIGGING MAINTENANCE:

##### STANDING RIGGING

YOUR BOAT IS EQUIPPED WITH STAINLESS STEEL STANDING RIGGING, AND DACRON RUNNING RIGGING TO GIVE YOU YEARS OF TROUBLE FREE SERVICE. HOWEVER, DUE TO NORMAL WEAR AND TEAR, IT IS RECOMMENDED THAT A PERIODIC INSPECTION BE MADE ON ALL FITTINGS AND WIRES. TURNBUCKLES SHOULD NEVER BE NEGLECTED AND SHOULD BE UNSCREWED FROM TIME TO TIME IN ORDER THAT THEY DO NOT SEIZE. EVERY THREE MONTHS SHOULD BE ABOUT RIGHT FOR THE AVERAGE SAILOR. A SLIGHTLY BENT TURNBUCKLE SHAFT OR BROKEN WIRE IN YOUR SHOULDERS SHOULD BE REPLACED IMMEDIATELY.

UNDER MOST CONDITIONS, 1 X 19 STANDING RIGGING HAS A SAFE "WORKING" LIFE SPAN OF APPROXIMATELY FIVE YEARS: SEVEN YEARS UNDER IDEAL CONDITIONS. FACTORS WHICH REDUCE THE LIFE OF THE WIRE ARE ENVIRONMENTAL FACTORS SUCH AS HIGH HUMIDITY (FLORIDA, THE CARIBBEAN, AND THE GULF STATES); HIGH SALINITY (GREAT SALT LAKE, GULF STATES, OR MOORING NEAR A SEA WALL WITH CONSTANT SALT SPRAY); EXTREMES IN TEMPERATURE; AND INDUSTRIAL POLLUTION (PULP MILLS, GENERATING PLANTS, ACID RAIN, AND SMOG). HIGH LOADING OF THE RIGGING ALSO INDUCES STRESS IN THE RIGGING SYSTEM.

MANY SAILORS HAVE TO DEAL WITH AT LEAST ONE OF THESE CONDITIONS AND SHOULD CONSIDER REPLACING STANDING RIGGING NEARER THE FIVE YEAR LIMIT.

UNLIKE RUNNING RIGGING WIRE ROPE, WHICH GIVES US CLEAR SIGNS THAT IT IS DETERIORATING BY BROKEN STRANDS AND "MEAT HOOKS", STANDING RIGGING MAY GIVE NO SIGN THAT FAILURE IS IMMINENT. THE USUAL POINT OF FAILURE OF STAY OR SHROUD IS APPROXIMATELY 1/4" INSIDE THE BOTTOM SWAGED THREADED STUD FITTING WHICH THREADS INTO THE TURNBUCKLE BARREL.

ALTHOUGH THE STUD IS COMPRESSED AROUND THE WIRE DURING THE SWAGING PROCESS, SALT WATER AND POLLUTANTS WORK DOWN INTO THE TINE CAVITIES BETWEEN THE WIRE STRANDS AND THE INEVITABLE CORROSION PROCESS STARTS IN THE CREVICE THE FIRST TIME THE RIGGING BECOMES WET WITH SALT WATER.

3.0 MAINTENANCE GUIDE CONT.

3.6 SPAR AND RIGGING MAINTENANCE CONT.

STANDING RIGGING CONT.

A COMMON METHOD OF VISUALLY MONITORING SWAGE FITTING CONDITIONS EMPLOYED BY DISTANCE RACERS AND CRUISERS IS TO DAB A SMALL RING OF ENAMEL PAINT AROUND THE JOINT BETWEEN THE WIRE AND THE SWAGE FITTING. THIS WILL HELP PROVIDE A MEANS TO SEE IF THE WIRE IS PULLING OUT OF THE FITTING.

ANOTHER TECHNIQUE USED TO CHECK THE CONDITION OF THE SWAGE FITTINGS IS A "DYE PENETRANT" TEST. THIS SIMPLE TEST WILL DETECT ANY CRACKS WHICH MAY DEVELOP IN THE FITTINGS DUE TO INTERNAL PRESSURE FROM THE CORROSIVE PROCESS. INEXPENSIVE DYE TEST KITS USUALLY ARE AVAILABLE AT MOST WELDING SUPPLY STORES. DYE TESTS USUALLY ARE NOT REQUIRED BY WEEKEND SAILORS, BUT MAY BE DONE BEFORE AN EXTENDED CRUISE OR OCEAN PASSAGE IF ANY DOUBT ABOUT THE INTEGRITY OF THE RIGGING EXISTS.

ALL STAINLESS STEEL WIRE ROPE RIGGING WILL DEVELOP SOME RUST FILM WHEN NEW. THIS IS NORMAL.

THE RUST IS CAUSED BY TWO FACTORS. WHEN WIRE ROPE IS MANUFACTURED, THE WIRE STRANDS ARE FED OVER STEEL ROLLERS DURING THE PROCESS OF TWISTING OR LAYING THE WIRE. TRACE AMOUNTS OF THE FERROUS STEEL FROM THE ROLLERS AND DYES ARE TRANSFERRED TO THE WIRE STRANDS. AS THIS SMALL AMOUNT OF STEEL RUSTS IT CAUSES A FILM ON THE NEW WIRE.

THE SECOND CAUSE OF THE RUST FILM ON NEW WIRE ROPE IS THE MICROSCOPIC VEINS OF FERROUS MATERIAL WHICH EXISTS IN ALL STAINLESS STEEL. AFTER A PERIOD OF TIME, AS THE SURFACE MATERIAL VEINS ARE DEPLETED, AND THE STAINLESS STEEL HAS BEEN CLEANED SEVERAL TIMES, NEW RUST FILM DEVELOPMENT WILL SLOW TO A MINIMUM.

FOR THE AVERAGE SAILOR, THE BEST INSURANCE AGAINST A RIGGING FAILURE IS A PERIODIC (EVERY SIX MONTHS IS RECOMMENDED) INSPECTION OF ALL RIGGING PARTS, INCLUDING TURNBUCKLES, AND REPLACEMENT OF STANDING RIGGING AS REQUIRED.



3.0 MAINTENANCE GUIDE CONT.

3.6 SPAR AND RIGGING MAINTENANCE CONT.

FITTINGS

MARINE FITTINGS TODAY NEED LITTLE MAINTENANCE. DECK HARDWARE SHOULD BE HOSED DOWN WITH FRESH WATER AFTER EACH SAIL IN SALT WATER. STAINLESS STEEL FITTINGS SUCH AS PULPITS AND LIFELINE STANCHIONS SHOULD BE CLEANED AND WAXED PERIODICALLY TO MAINTAIN THEIR APPEARANCE. WINCHES REQUIRE OCCASSIONAL CLEANING AND LUBRICATION. WHERE POSSIBLE, A MAINTENANCE BROCHURE FOR YOUR WINCHES HAS BEEN INCLUDED IN THIS MANUAL. MASTHEAD FITTINGS, HALYARD SHEAVES, ETC., SHOULD BE INSPECTED, CLEANED, AND LUBRICATED PERIODICALLY. KEEP YOUR EQUIPMENT CLEAN OF DIRT AND SALT.

SPARS

LIKE ALL OTHER FITTINGS, MAST AND BOOMS SUFFER FROM SALT WATER, AIR AND SPRAY. THESE SHOULD BE KEPT WAXED WHERE POSSIBLE, AND AT LEAST ALWAYS HOSED DOWN WITH FRESH WATER. ALWAYS SEE THAT THE HALYARDS ARE TIED OFF AWAY FROM THE MAST. THIS WILL ELIMINATE SLAPPING IN THE WIND, AND SUBSEQUENT MARKING OF THE MAST. KEEP TACK PIN (WHICH IS LOCATED ON FRONT OF BOOM) WELL LUBRICATED, AS THE STAINLESS STEEL PIN CAN BECOME SEIZED IN THE ALUMINUM GOOSENECK CASTING WITHOUT THE PROPER LUBRICATION.

FIND A HIGH PRESSURE NOZZLE AND SHOOT FRESH WATER TO THE TOP OF THE MAST AND SPREADERS. THIS WILL HELP KEEP YOUR SAILS CLEAN TOO, AS THEY RUB ON THE MAST AND SPREADERS.

INSPECT SPREADERS AND SPREADER BRACKERS FOR SIGNS OF FATIGUE. SEE THAT ENDS OF SPREADERS ARE WIRED AND WELL COVERED WITH TAPE TO PREVENT WEAR ON THE SAILS.

3.7 SAIL MAINTENANCE:

SAILS SHOULD NEVER BE PUT AWAY WET. IF THEY ARE WET AFTER SAILING, LEAVE THEM IN LOOSE BUNDLES AND DRY THEM AT YOUR FIRST OPPORTUNITY.

FOR MOST PROBLEMS SUCH AS COMMON DIRT, DRIED OR CAKED SALT, ETC., TRY SCRUBBING THE SURFACE WITH A SOFT BRISTLE BRUSH AND LIQUID DETERGENT. AVOID HARSH POWDER DETERGENTS AND STIFF BRUSHES AS THEY MAY DAMAGE THE FINISH OR STITCHING. THIS APPROACH SHOULD WORK NICELY FOR MOST APPLICATIONS. MORE SEVERE STAINS CAN BE TAKEN CARE OF BY THE FOLLOWING:

\* \* IMPORTANT: FOR WHITE SAILS ONLY \* \*

BLOOD: SOAK THE STAINED PORTION FOR 10 - 20 MINUTES IN A SOLUTION OF BLEACH (CLOROX) AND WARM WATER. GENERALLY 10 (TEN) PARTS WATER TO 1 (ONE) PART BLEACH. SCRUB AND REPEAT IF NECESSARY. RINSE THOROUGHLY, PARTICULARLY NYLON, AND DRY COMPLETELY.

3.0 MAINTENANCE GUIDE CONT.

3.7 SAIL MAINTENANCE CONT.

OIL, GREASE, TAR AND WAX: WARM WATER, SOAP AND ELBOW GREASE SEEM TO BE EFFECTIVE. ON HARD STAINS, PROPRIETY STAIN REMOVER AND DRY CLEANING FLUIDS SHOULD DO THE TRICK. BE CAREFUL TO REMOVE ALL FLUIDS, AS THEY CAN SOFTEN THE VARIOUS RESINATED COATINGS ON SAILCLOTH.

RUST AND METALLIC STAINS: THESE TYPES OF STAINS ARE VERY OFTEN THE MOST FRUSTRATING AND DIFFICULT TO REMOVE. FIRST SCRUB WITH SOAP AND WATER, AND APPLY ACETONE, M.E.K., OR ALCOHOL. AS A LAST RESORT, YOU MIGHT TRY A DILUTED MIXTURE (5%) OF OXALIC SOAKED FOR 15 - 20 MINUTES. HYDROCHLORIC ACID, 2 PARTS TO 100 IN WARM WATER, WILL ALSO WORK.

MILDEW: HOT SOAPY WATER WITH A LITTLE BLEACH WILL GENERALLY PREVAIL. AFTER SCRUBBING, LEAVE THE SOLUTION ON THE FABRIC FOR A FEW MINUTES AND RINSE THOROUGHLY. WHEN USING A BLEACH, A RESIDUAL CHLORINE SMELL MAY BE PRESENT AFTER RINSING. A 1% SOLUTION OF THIOSULPHATE (PHOTOGRAPHER'S HYPO) SHOULD REMOVE ALL TRACES OF CHLORINE. HERE AGAIN, RINSE AND DRY WELL.

PAINT AND VARNISH: ACETONE AND M.E.K. SHOULD REMOVE MOST COMMON PAINT AND STAINS. VARNISH CAN BE EASILY REMOVED WITH ALCOHOL.

TEMPERKOTE OR MYLAR SAILS ARE STILL NEW AND EXPERIMENTAL. AT THIS POINT IN TIME, AVOID MOST SOLVENTS, AS THEY CAN DAMAGE THE FABRIC OVER A PERIOD OF TIME. SOAP AND DILUTED BLEACHES SHOULD TAKE CARE OF MOST STAINS.

GENERALLY SPEAKING, USE ALL SOLVENTS WITH CARE. ALWAYS RINSE AND DRY THOROUGHLY. IT SHOULD BE EMPHASIZED THAT NYLON RIPSTOP SPINNAKER FABRICS ARE LESS DURABLE AND MORE SENSITIVE THAN THEIR POLYESTER COUNTERPARTS. BLEACHES AND SOLVENTS CAN RUIN NYLON IF NOT PROPERLY USED.

FOLLOW THE GUIDELINES, TAKE YOUR SAILS IN TO YOUR SAILMAKER FOR PERIODICAL INSPECTION AND YOU WILL HAVE MANY EFFECTIVE SEASONS OF RACING AND CRUISING PLEASURE.



3.0 MAINTENANCE GUIDE CONT.

3.8 INTERIOR CUSHION, FABRIC COVER:

CLEANING

1. REGULAR VACUUM CLEANING OR BRUSHING IN THE DIRECTION OF THE PILE WITH A SOFT BRUSH.
2. STAINS SHOULD, IF POSSIBLE, BE REMOVED AT ONCE WITH A DAMP CLOTH. DO NOT ALLOW STAINS TO HARDEN OR AGE.
3. GREASY STAINS CAN BE REMOVED WITH ORDINARY CLEANING FLUID.
4. FOR OVERALL CLEANING, USE COMMERCIAL TYPES OF FOAM UPHOLSTRY SHAMPOO. USE ONLY THE FOAM TO PROTECT THE BACK PADDING FROM MOISTURE, AFTER A MINUTE OR SO, REMOVE FOAM, AND WHEN DRY, VACUUM OR BRUSH IN THE DIRECTION OF THE PILE.
5. DO NOT USE HEAT SUCH AS AN IRON OR STEAM.

3.8.1 CURTAINS

WHEN CURTAINS BECOME SOILED, DO NOT HAND OR MACHINE WASH, AS IT WILL WEAKEN THE MATERIAL. DRY CLEANING IS THE RECOMMENDED PROCEDURE FOR THE REMOVAL OF ANY DIRT OR STAINS.

4.0 Y A C H T S Y S T E M S

4.1 RIGGING:

4.1.1 TUNING THE MAST

YOUR MAST IS HELD ALOFT BY THE STANDING RIGGING (FORESTAY, BACKSTAY, UPPER SHROUDS, FORE AND AFT LOWER SHROUDS). THE TERM 'TUNING' REFERS TO ADJUSTMENT OF THE STANDING RIGGING SO THAT THE MAST REMAINS 'IN COLUMN' (NOT BENT) WHEN UNDER LOAD. THIS IS ACCOMPLISHED BY FOLLOWING THE PROCEDURE OUTLINED BELOW:

AT THE DOCK

1. ADJUST FORESTAY AND BACKSTAY SO THAT THE MAST IS STRAIGHT UP AND DOWN. TIE A BOLT TO A 6 TO 7 FOOT LONG PIECE OF LIGHT LINE TO MAKE A QUICK PLUMB BOB, AND TAPE THE FREE END OF THE LINE TO THE FRONT OF THE MAST AS HIGH UP AS YOU CAN REACH. THIS DEVICE WILL HELP YOU TO DETERMINE WHETHER THE MAST IS PERPENDICULAR OR NOT. OTHERWISE, SIGHT YOUR MAST WITH A CORNER OF A BUILDING.
2. ADJUST UPPER SHROUDS SO MAST IS STRAIGHT UP AND DOWN ATHWARTSHIPS. THAT IS, FROM SIDE TO SIDE AS OPPOSED TO BOW AND STERN.
3. THE UPPER SHROUDS SHOULD BE FIRM BUT NOT FAR APART. A 50 POUND PUSH SHOULD DEFLECT THE UPPER SHROUD ABOUT 1" AT SHOULDER HEIGHT.
4. THE LOWER SHROUDS (4 OF THEM) SHOULD BE ADJUSTED SO THAT THEY ARE LOOSER THAN THE UPPER SHROUDS. WHILE AT DOCK, THEY SHOULD HAVE NO SLACK, BUT NO TENSION EITHER. NO LOWER SHROUDS, WHEN PUSHED, SHOULD DEFLECT THE MAST MORE THAN ANY OTHER SHROUD WHEN PUSHED EQUALLY HARD. IF THIS CAN NOT BE ACHIEVED, THE UPPER SHROUDS ARE TOO TIGHT. BACK OFF ONE-HALF TURN AT A TIME ON THE UPPER SHROUD TURNBUCKLES UNTIL THE TENSION OF THE LOWER SHROUDS IS BROUGHT INTO BALANCE.

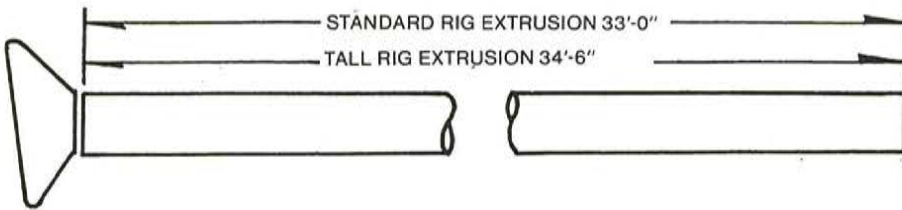

TURNBUCKLES	QTY
5/16" WITH 5/16" PIN	8

MISC. RIGGING		
DESCRIPTION	LENGTH	QTY.
DOWNHAUL, DACRON	1/4" x 5'-0"	1
MAINSHEET, DACRON	3/8" x 75'-0"	1
TOPPING LIFT	1/4" x 16'-0"	1
REEFING LINE	5/16" x 11'-0"	1
REEFING LINE (INTERNAL, AFT)	5/16" x 19'-0"	1
TRAVELER ADJUSTER LINES	5/16" x 12'-0"	2
BACKSTAY ADJUSTER LINE, DACRON	5/16" x 20'-0"	1
VANG LINE, DACRON	5/16" x 35'-0"	1
FOREGUY, DACRON	3/8" x 35'-0"	1
SPINNAKER HALYARD, DACRON	3/8" x 75'-0"	1

DESCRIPTION	LENGTH		MATERIALS	QTY.
	STD.	TALL		
BACKSTAY	36'-10"	38'-2 1/2"	3/16" Ø 1 x 19	1
FORESTAY	34'-11 1/2"	36'-6"	3/16" Ø 1 x 19	1
UPPERS	33'-8"	35'-2 1/2"	3/16" Ø 1 x 19	2
AFT. LOWERS	17'-4"	18'-9 1/2"	5/32" Ø 1 x 19	2
FWD. LOWERS	17'-1/2"	18'-6"	5/32" Ø 1 x 19	2
BACKSTAY BRIDLE	5'-8 1/2"	5'-8 1/2"	3/16" Ø 1 x 19	2
TOPPING LIFT	29'-3"	30'-9"	1/8" Ø 7 x 19	1
BACKSTAY (SPLIT)	31'-2 1/4"	32'-7 3/4"	3/16" Ø 1 x 19	1
JIB HALYARD	78'-0"	82'-0"	5/16" Ø L.S. DACRON	2
MAIN HALYARD	78'-0"	82'-0"	5/16" Ø L.S. DACRON	1
110% LAPPER	55'-0"	55'-0"	3/8"	1
150% GENOA	75'-0"	75'-0"	3/8"	1
150% GENOA (FURLING)	75'-0"	75'-0"	3/8"	1
129% GENOA	N/A	75'-0"	3/8"	1

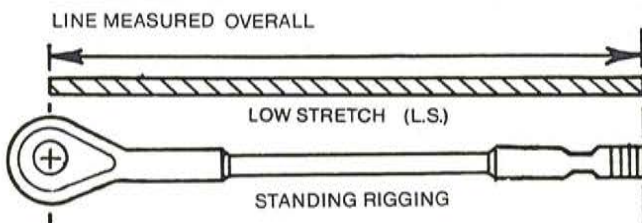

RIGGING MEASURED FROM  
END OF STUD TO  
CENTER OF EYE

CATALINA YACHTS INC.  
21200 VICTORY BLVD.  
WOODLAND HILLS, CA

RIGGING WIRE LENGTH CHECKLIST

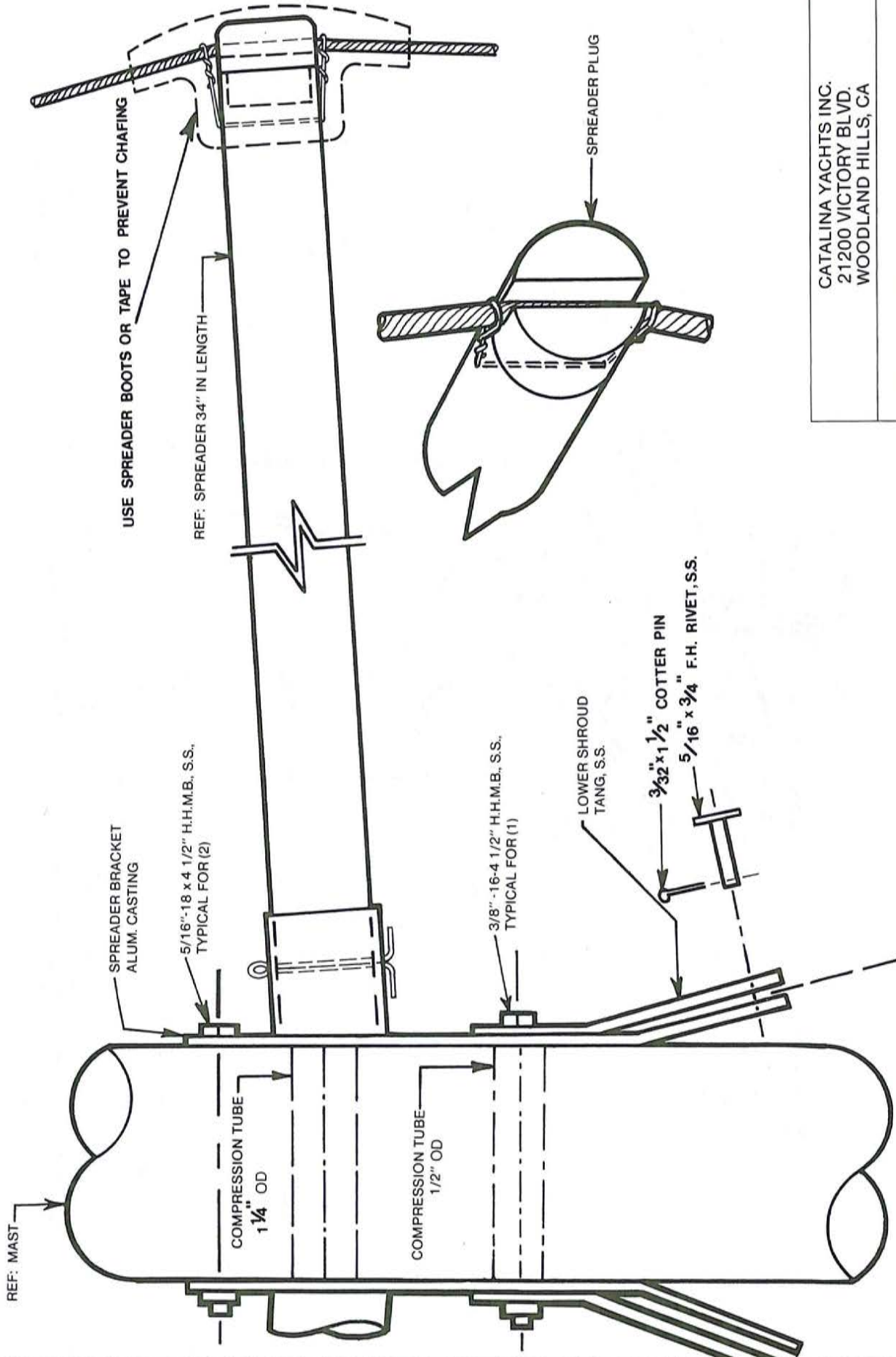

CATALINA YACHTS INC.  
 21200 VICTORY BLVD.  
 WOODLAND HILLS, CA

SPREADER BRACKET ASSEMBLY

CATALINA 27 OWNERS MANUAL

4.1.4



MASTHEAD CRANE FOR USE WITH SPINNAKER HALYARD

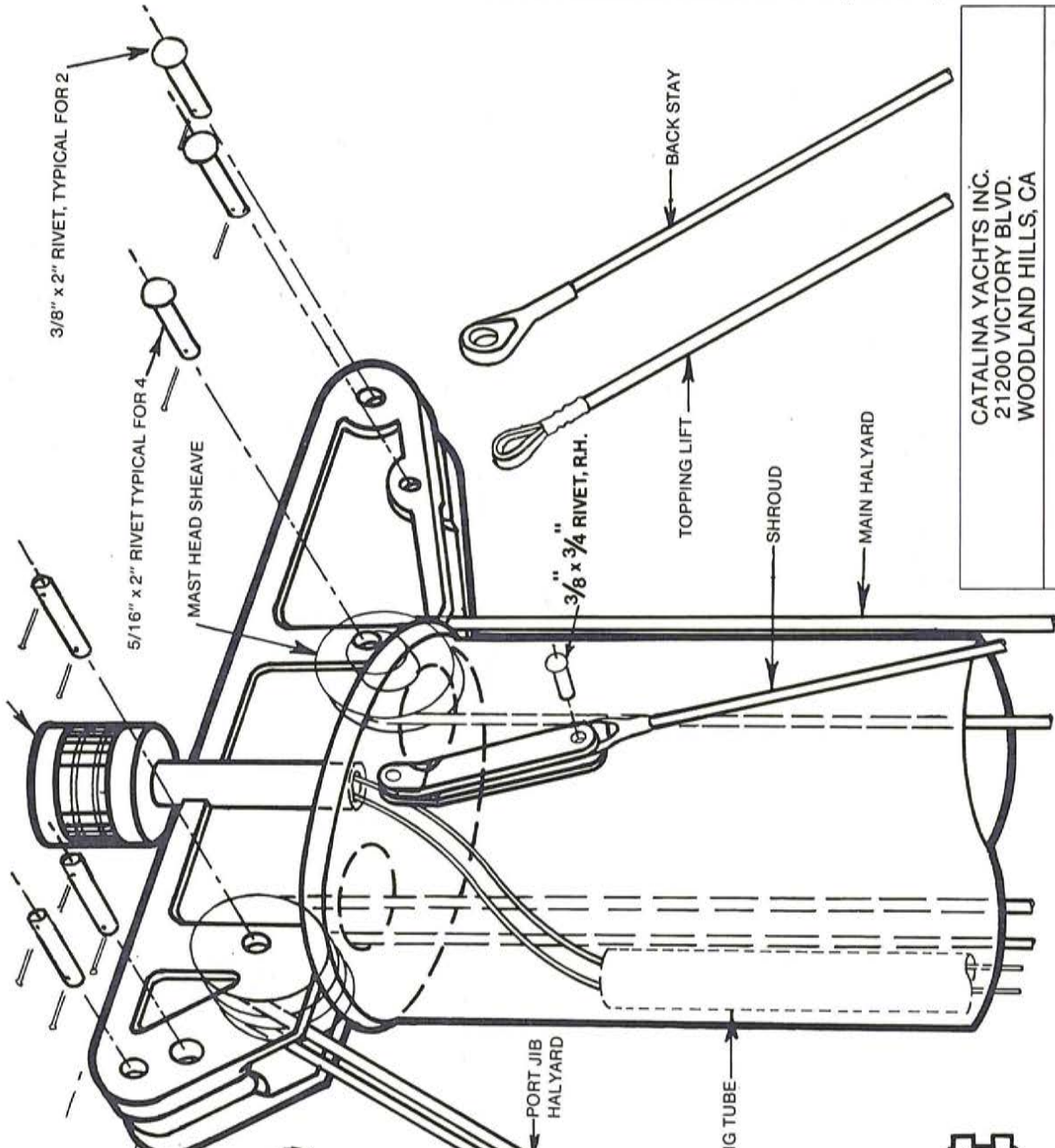

CATALINA YACHTS INC.  
 21200 VICTORY BLVD.  
 WOODLAND HILLS, CA

INTERNAL HALYARD MASTHEAD ASSEMBLY

CATALINA 27 OWNERS MANUAL

4.1.5

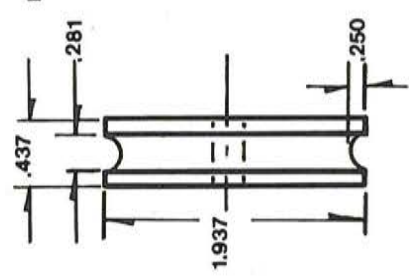

MAST HEAD SHEAVE

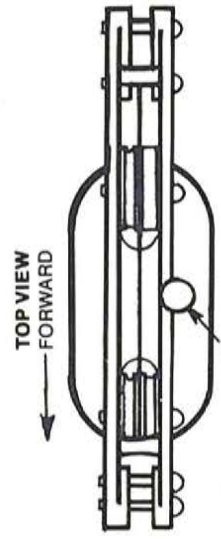

REF: ANCHOR LIGHT

## 4.0 YACHT SYSTEMS CONT.

### 4.1.6 MAIN SAIL REEFING

REEFING SHOULD ALWAYS BE DONE BEFORE IT BECOMES NECESSARY. SOME SAILORS USE THE RULE OF THUMB THAT, IF THE THOUGHT OF REEFING OCCURS TO YOU, IT IS TIME TO REEF. SAILING AT EXTREME ANGLES OF HEEL - 25 DEGREES OR MORE - IS NOT EFFICIENT, FAST OR COMFORTABLE.

THE CATALINA 27 IS EQUIPPED WITH JIFFY REEFING. THE SYSTEM CONSISTS OF A SINGLE REEFING SHEAVE MOUNTED ON THE END OF THE BOOM. A CLAM CLEAT IS LOCATED ON THE BOTTOM OF THE BOOM NEAR THE GOOSENECK TO TIE OFF THE REEFING LINE. ANOTHER CLEAT IS LOCATED ON THE MAST BELOW THE GOOSENECK FOR REEFING THE LUFF OF THE MAIN.

RUN THE REEFING LINE PROVIDED THROUGH THE CRINGLES (GROMMETS) IN THE LUFF AND LEECH OF THE MAIN SAIL IN PREPARATION FOR REEFING. PER ILLUSTRATION, ONE CREW STATIONED IN THE COCKPIT AND ONE CREW AT THE MAST ARE RECOMMENDED FOR FAST, SAFE REEFING.

#### REEFING PROCEDURE:

1. TAKE UP SLACK IN MAIN BOOM TOPPING LIFT, CLEATED TO PORT SIDE OF BOOM.
2. RELEASE THE MAIN HALYARDS TO A PREDETERMINED POINT. MARKING THE HALYARD WITH INK OR A COLORED THREAD WOVEN INTO THE LINE IS HELPFUL. RE-CLEAT THE HALYARD AFTER LOWERING.
3. PULL THE LUFF CRINGLE DOWN TO THE GOOSENECK BY PULLING THE LUFF REEFING LINE THROUGH THE CLEAT ON EITHER SIDE OF THE MAST. BY PULLING THE LINE UP THROUGH THE CLEAT, A 2:1 PURCHASE IS CREATED ON THE LUFF. TIE OFF THE LUFF REEFING LINE WHEN THE CRINGLE MEETS THE GOOSENECK.
4. EASE THE MAINSHEET.
5. PULL THE LEECH CRINGLE DOWN TO THE BOOM BY PULLING THE LEECH REEFING LINE ON THE STARBOARD SIDE OF THE BOOM, AND MAKE THE LINE FAST.
6. TRIM IN THE MAINSHEET.
7. SNUG UP THE MAIN HALYARD, AS REQUIRED, TO FLATTEN OUT THE MAIN SAIL.
8. TIE IN ADDITIONAL LIGHT LINES BETWEEN THE FORWARD AND AFT REEFPOINTS, THROUGH THE CRINGLES IN THE SAIL AS REQUIRED TO KEEP THE SAIL BUNDLED NEATLY AND THE SAIL SHAPE FLAT.

SEE PAGE 25 FOR  
REEFING INSTRUCTIONS

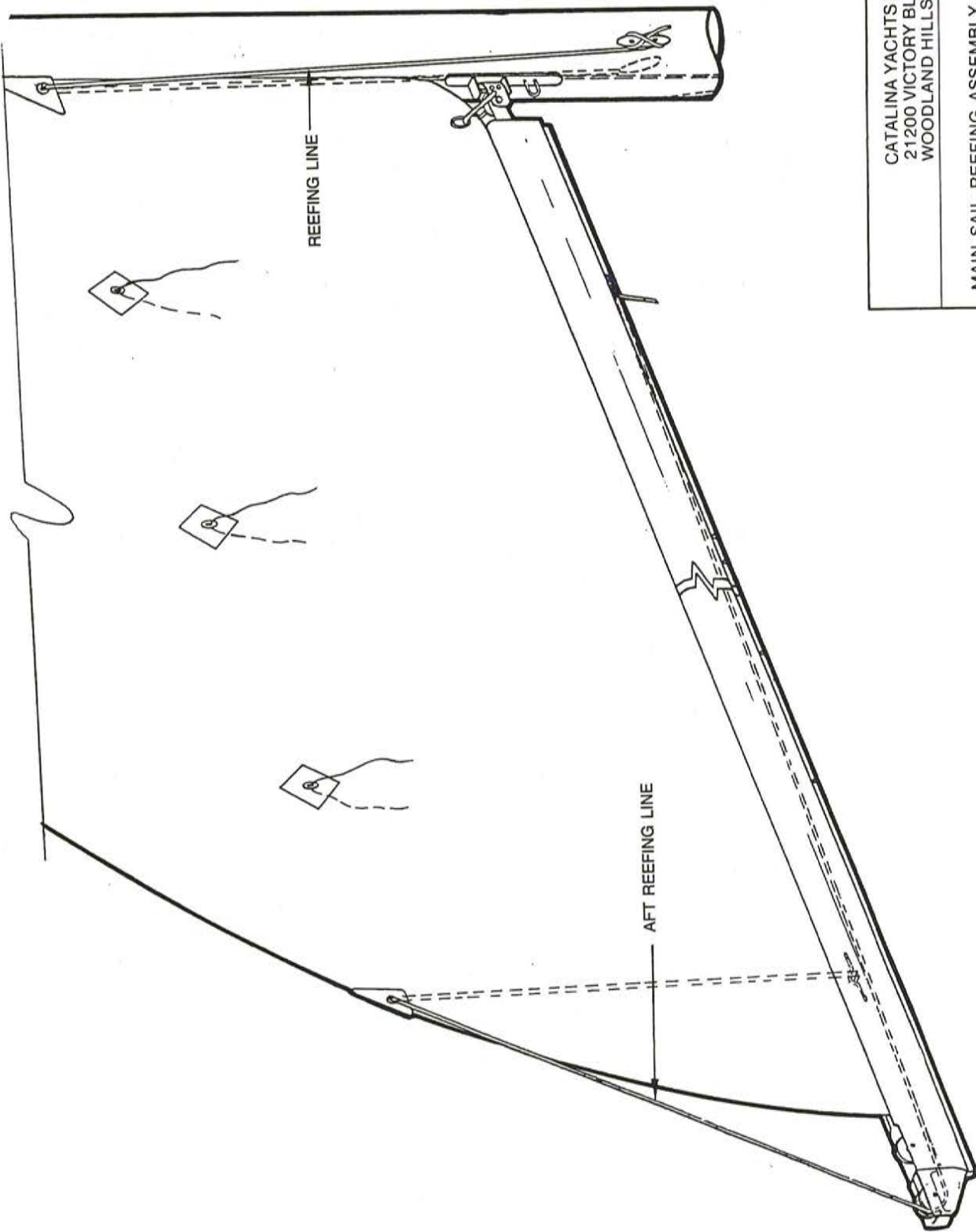

CATALINA YACHTS INC.  
21200 VICTORY BLVD.  
WOODLAND HILLS, CA

MAIN SAIL REEFING ASSEMBLY

CATALINA 30 OWNERS MANUAL

4.1.7



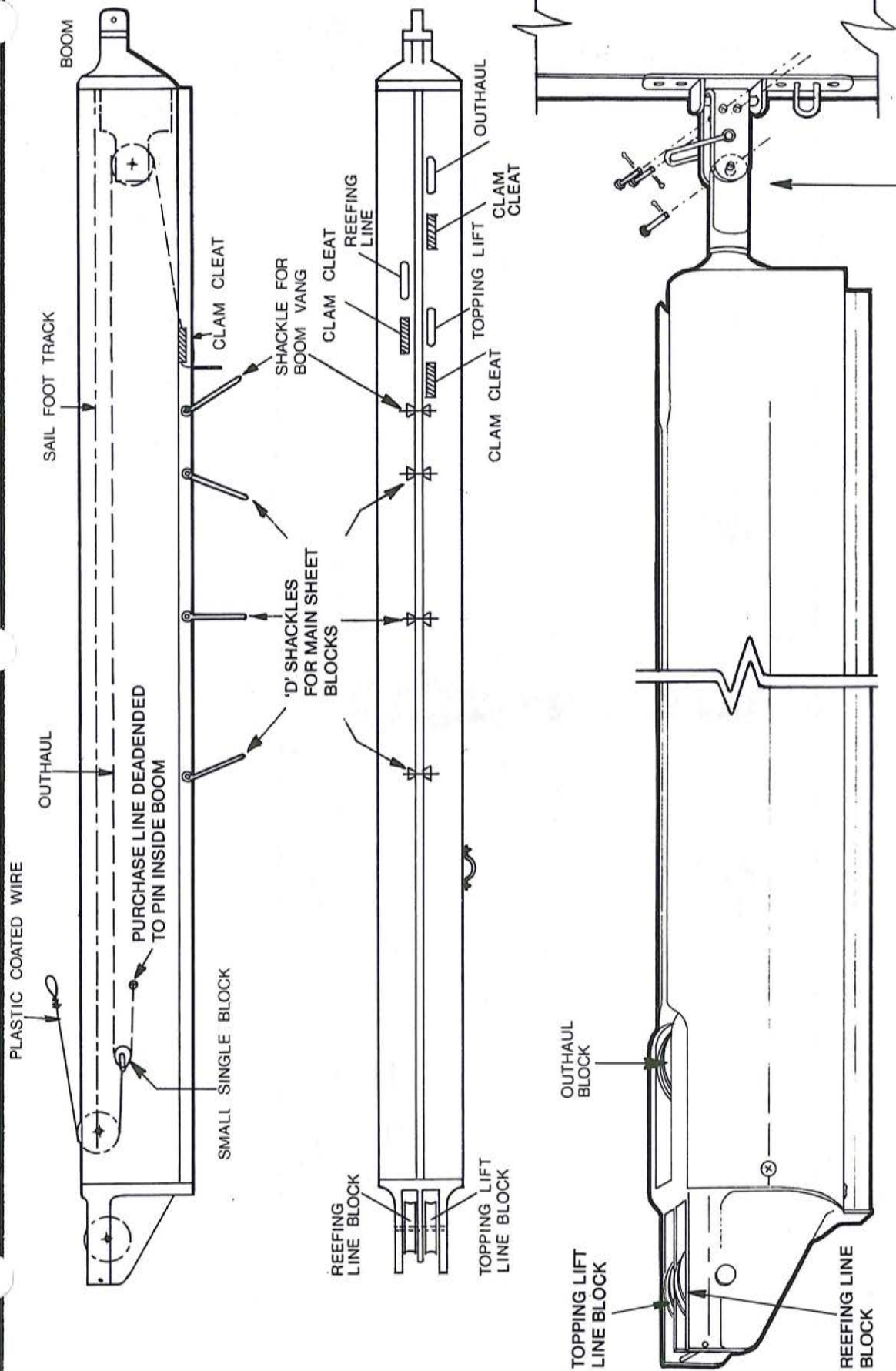

GOOSENECK ASSEMBLY

CATALINA YACHTS INC.  
 21200 VICTORY BLVD.  
 WOODLAND HILLS, CA

ADJUSTABLE OUTHAUL

CATALINA 27 OWNERS MANUAL

4.1.8

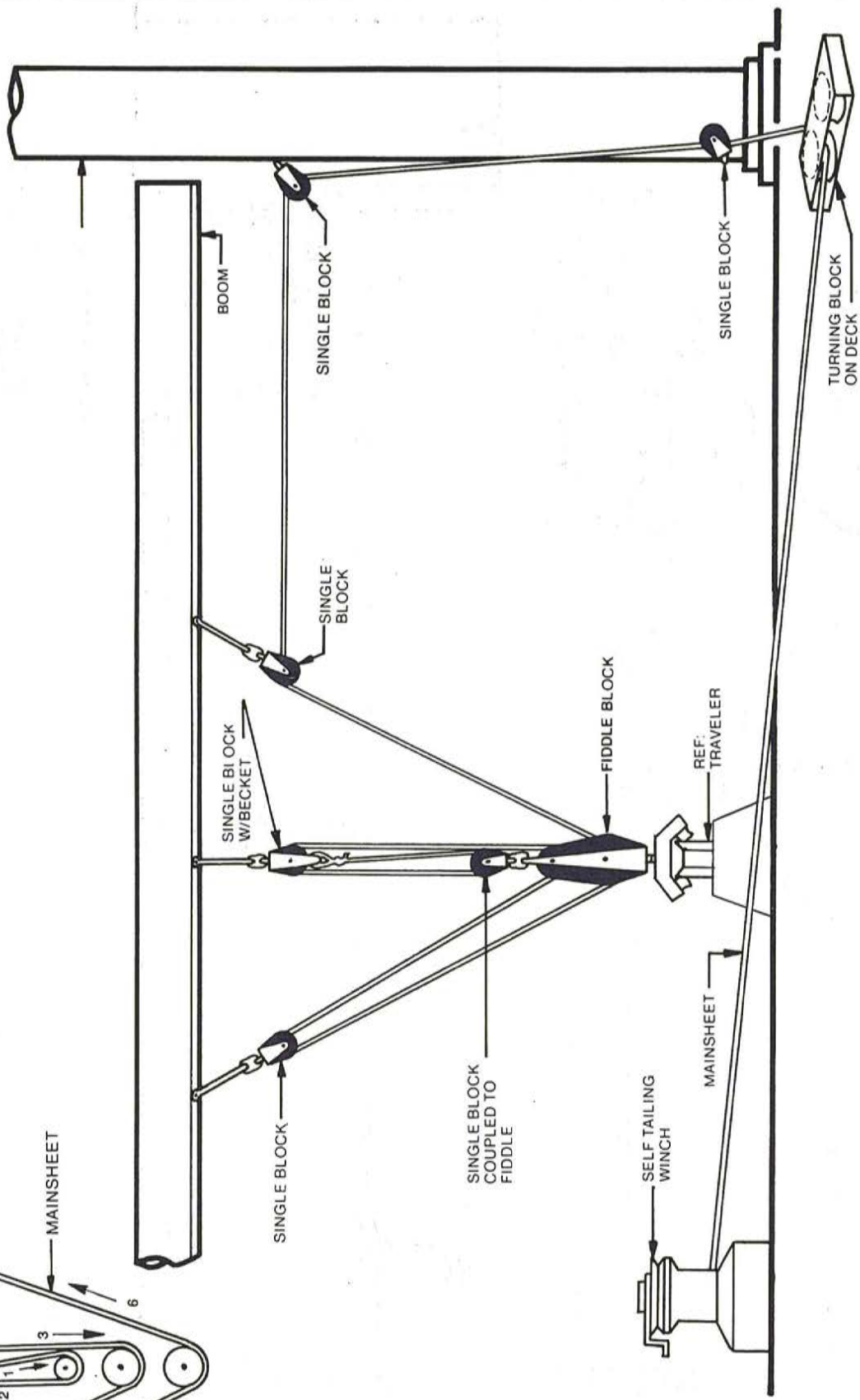
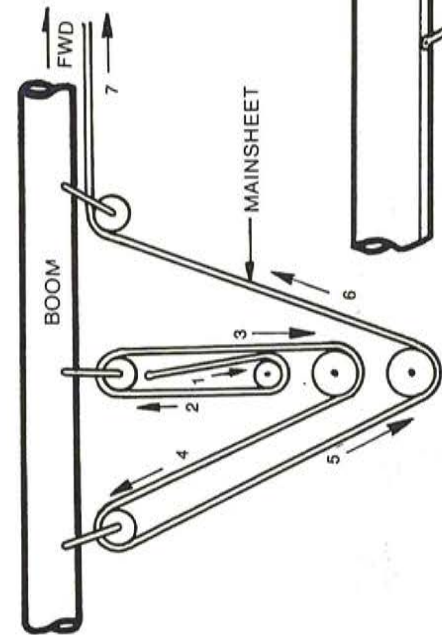

CATALINA YACHTS INC.  
 21200 VICTORY BLVD.  
 WOODLAND HILLS, CA

**MAINSHEET RIGGING**

CATALINA 27 OWNERS MANUAL 4.1.9

TOP VIEW  
TRAVELER ASSEMBLY

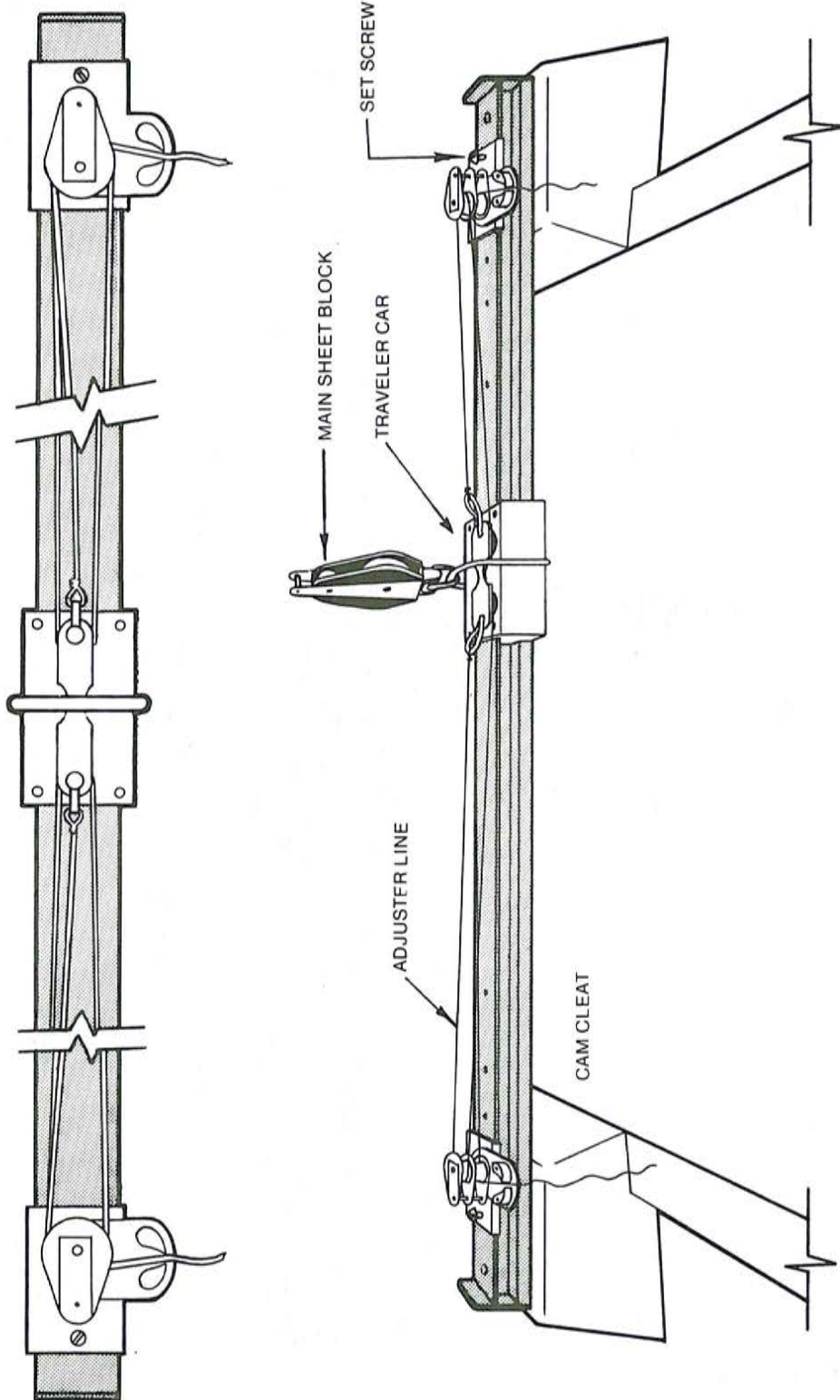

CATALINA YACHTS INC.  
21200 VICTORY BLVD.  
WOODLAND HILLS, CA

TRAVELER ASSEMBLY

CATALINA 27 OWNERS MANUAL 4.1.10



(2) SPEED SELF TAILING WINCH

DOUBLE SHEET STOPPER WITH SECOND HALYARD OPTION

PORT JIB HALYARD

STBD. JIB HALYARD

REF. TRAVELER CAR

REF. TRAVELER

MAINSHEET

MAIN HALYARD

DECK ORGANIZER BLOCK

CLAM CLEAT WITH LOCK OUT

SINGLE SHEET STOPPER

STBD. JIB HALYARD

PORT JIB HALYARD

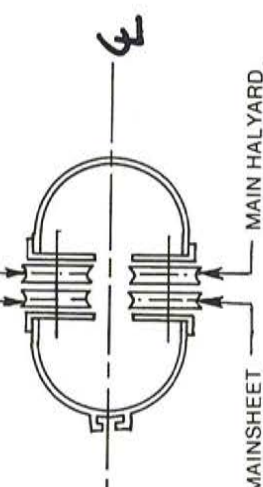

CATALINA YACHTS INC.  
21200 VICTORY BLVD.  
WOODLAND HILLS, CA

HALYARD ARRANGEMENT

CATALINA 27 OWNERS MANUAL 4.1.11

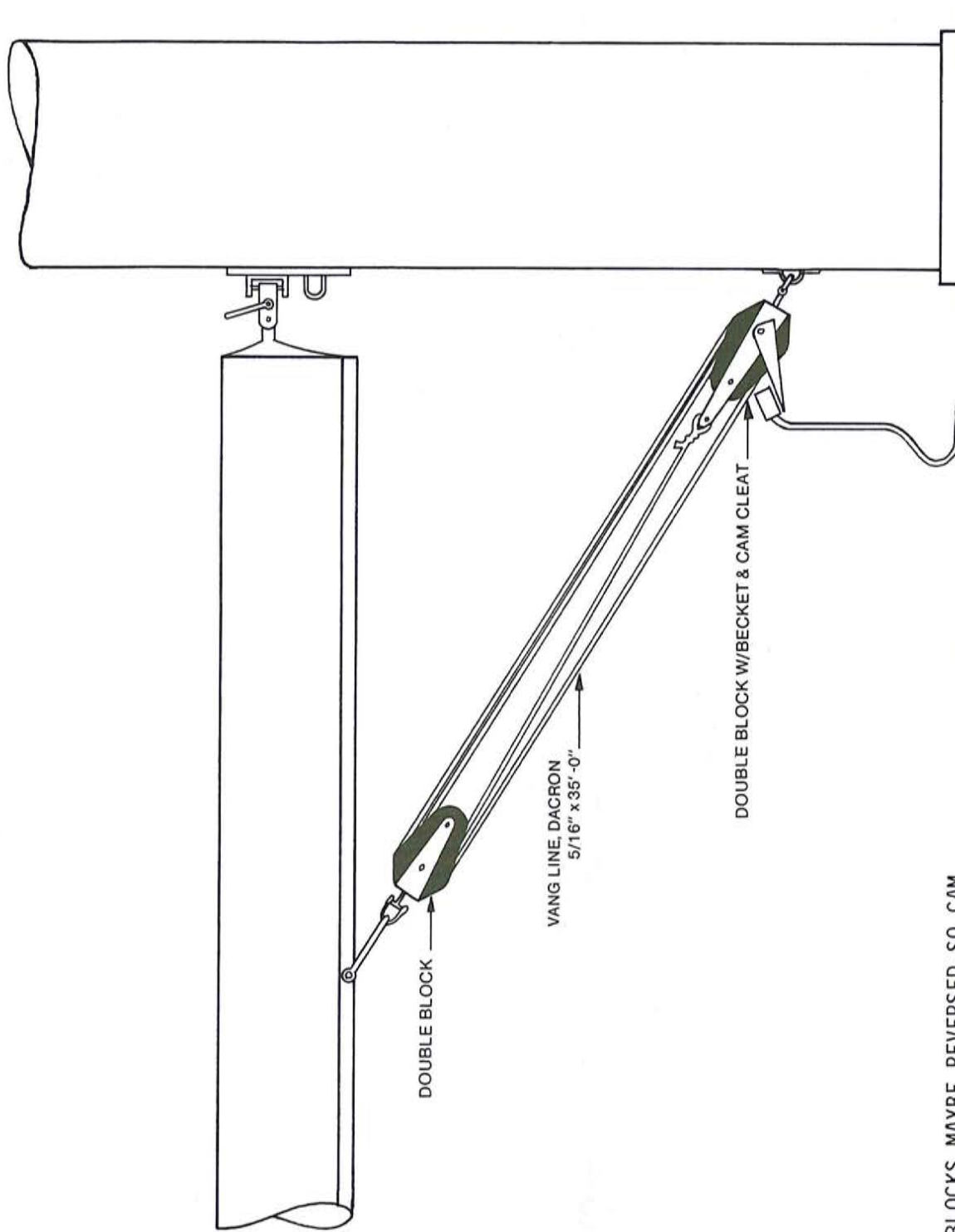

NOTE: BLOCKS MAYBE REVERSED SO CAM IS AT TOP, AT OWNERS OPTION.

CATALINA YACHTS INC.  
21200 VICTORY BLVD.  
WOODLAND HILLS, CA

BOOM VANG ARRANGEMENT

CATALINA 27 OWNERS MANUAL

4.1.12

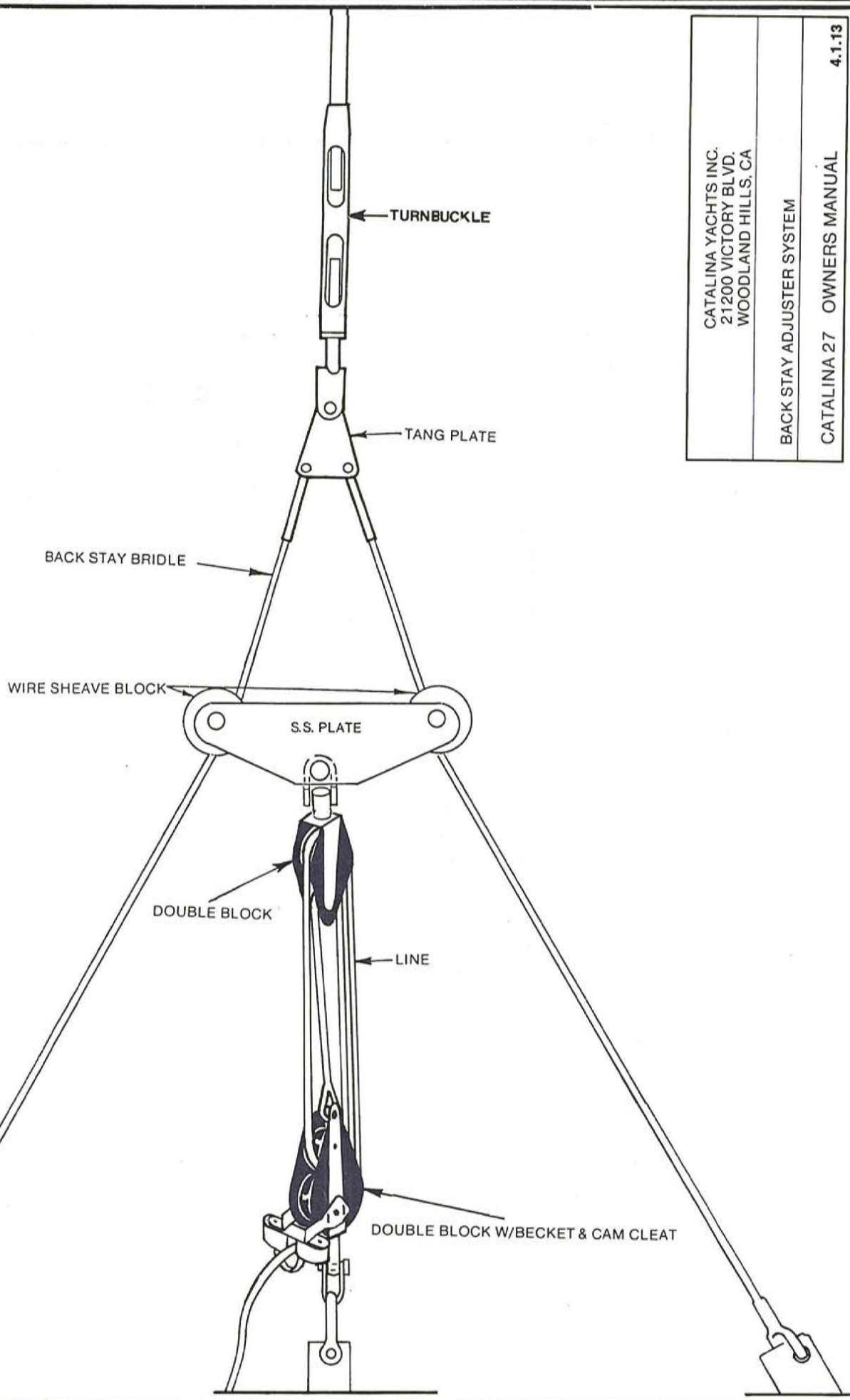

CATALINA YACHTS INC.  
 21200 VICTORY BLVD.  
 WOODLAND HILLS, CA

BACK STAY ADJUSTER SYSTEM

CATALINA 27 OWNERS MANUAL

4.1.13



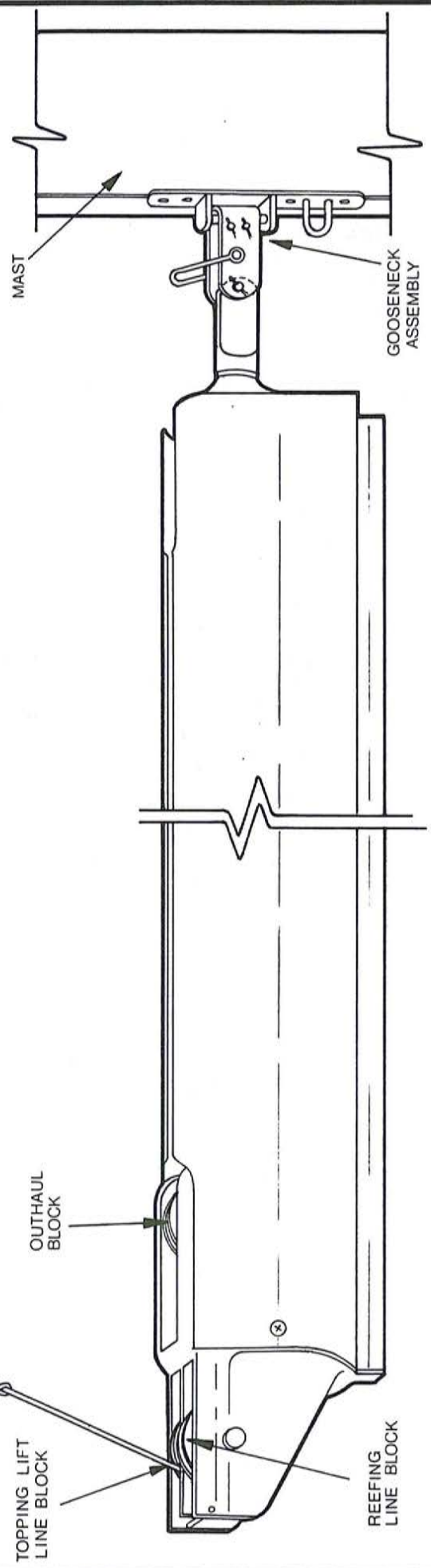
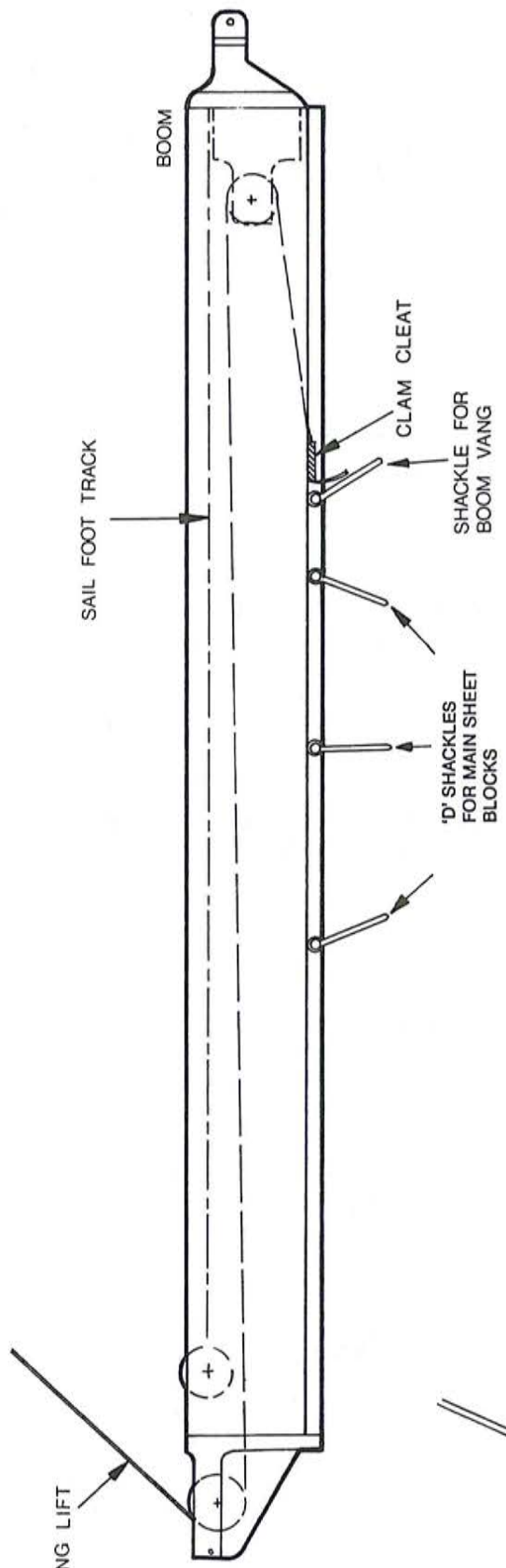

CATALINA YACHTS INC.  
 21200 VICTORY BLVD.  
 WOODLAND HILLS, CA

TOPPING LIFT ASSEMBLY

CATALINA 27 OWNERS MANUAL

4.1.14

4.0 YACHT SYSTEMS CONT.

4.2 ELECTRICAL

4.2.1 BATTERIES

YOUR ELECTRICAL SYSTEM IS POWERED BY A MARINE GRADE 12 VOLT, DEEP CYCLE 90 AMP HOUR BATTERY. ATTENTION SHOULD BE GIVEN TO MAINTAINING THE PROPER LEVEL OF DISTILLED WATER. DO NOT OVERFILL. THE BATTERIES ARE LOCATED IN THE PORT COCKPIT LOCKER.

THE BATTERIES ARE PROVIDED WITH A TIE DOWN TO PREVENT TIPPING OVER AT EXTREME ANGLES OF HEEL. BE SURE THESE TIE DOWNS ARE FASTENED SECURELY.

WITH PROPER CARE, THE BATTERY INSTALLED IN YOUR CATALINA 27 WILL PROVIDE LONG AND SATISFACTORY SERVICE. PROPER CARE IS NOT DIFFICULT IF A FEW BASIC POINTS ARE KEPT IN MIND.

WARNING

THE ELECTROLYTE IN A BATTERY IS A SOLUTION OF SULPHURIC ACID. IF ANY SHOULD ENTER THE EYES, RINSE IMMEDIATELY WITH LARGE AMOUNTS OF FRESH WATER AND SEEK MEDICAL ATTENTION. ELECTROLYTE SPILLED ON SKIN SHOULD BE RINSED WELL WITH FRESH WATER, ALSO. EVEN A SMALL AMOUNT OF ELECTROLYTE SPILLED ON CLOTHING WILL DESTROY THE CLOTHING.

ELECTROLYTE LEVEL

THE ELECTROLYTE LEVEL IN A BATTERY SHOULD NEVER BE ALLOWED TO FALL LOW ENOUGH TO EXPOSE THE PLATES. THIS NOT ONLY RESULTS IN A LOSS OF BATTERY CAPACITY WHILE THE BATTERY IS LOW, BUT WILL RESULT IN A PERMANENT LOSS OF BATTERY CAPACITY.

CAUTION

USE ONLY PURE DISTILLED WATER TO REPLENISH ELECTROLYTE LEVELS. THE WATER FROM MANY CITY WATER SUPPLY SYSTEMS IS UNSATISFACTORY FOR BATTERY USE.

DISCHARGED STATE

LEAVING A BATTERY IN A DISCHARGED STATE FOR ANY LENGTH OF TIME CAN ALSO RESULT IN A PERMANENT LOSS OF CAPACITY FOR THE BATTERY. DOING SO, IN COLD WEATHER, CAN DESTROY THE BATTERY, SINCE IT WILL FREEZE AT RELATIVELY LOW TEMPERATURES.

CLEAN CONNECTIONS

KEEP BATTERY CONNECTIONS CLEAN AND TIGHT. A CUPFUL OF STRONG BAKING SODA SOLUTION AND A TOOTHBRUSH WILL CLEAN CORROSION FROM THE TERMINALS, AND NEUTRALIZE ANY SPILLED ACID. (DO NOT ALLOW ANY OF THE SOLUTION TO ENTER THE BATTERY CELLS.) A COATING OF PETROLEUM JELLY ON THE BATTERY TERMINALS WILL INHIBIT CORROSION.



4.0 YACHT SYSTEMS CONT.

4.2 ELECTRICAL CONT.

4.2.2 110 VOLT SYSTEM

THE OPTIONAL 110 VOLT AC SYSTEM IS CONNECTED TO SHORE POWER BY A GROUNDED TWIST-LOCK CONNECTOR MOUNTED ON THE OUTSIDE OF THE PORT COCKPIT COAMING.

A 30 AMP, TWO-POLE CIRCUIT BREAKER IS LOCATED ON THE MAIN PANEL. FOUR (4) DUPLEX OUTLETS FOR THE 110 VOLT SYSTEM ARE LOCATED IN THE CABIN. BE CERTAIN THAT ALL 110 VOLT APPLIANCES, OTHER THAN LAMPS, HAVE AN ADEQUATE GROUNDING CONNECTOR. WET FEET OR MOIST ATMOSPHERE INCREASES THE POTENTIAL SHOCK HAZARD.

CIRCUIT GUARD RECEPTACLES ARE DESIGNED TO PROVIDE PROTECTION AGAINST ELECTRICAL SHOCK HAZARDS DUE TO LINE-TO-GROUND FAULTS. ALTHOUGH THE CIRCUIT GUARD RECEPTACLE DOES NOT LIMIT THE MAGNITUDE OF THE FAULT CURRENT, AND THEREFORE CANNOT PREVENT ELECTRIC SHOCK, IT DOES LIMIT THE DURATION OF THE SHOCK TO A PERIOD CONSIDERED SAFE FOR NORMAL HEALTHY PERSONS. CIRCUIT GUARD RECEPTICLES WILL PROVIDE PROTECTION AGAINST GROUND FAULTS ONLY. THEY WILL NOT PROTECT AGAINST OVERLOADS OR SHORT CIRCUITS. THERE IS NO KNOWN DEVICE THAT WILL GUARD AGAINST THE ELECTRICAL SHOCK HAZARD RESULTING FROM CONTACT WITH BOTH THE "HOT" AND NEUTRAL WIRES OF THE ELECTRICAL CIRCUIT.

**WARNING:** DO NOT OPEN THE ELECTRICAL PANEL FOR ANY PURPOSE WITH THE 110 VOLT SHORE POWER CONNECTED TO THE DOCK. 110 VOLT WIRING IS EXPOSED WHEN THE PANEL IS OPEN. CONTACT WITH 110 VOLT WIRING CAN CAUSE ELECTROCUTION! ELECTRICITY IS DANGEROUS. EVEN WHEN SAFETY DEVICES ARE PRESENT, HANDLE WITH CARE AND USE REASONABLE CAUTION.

TO MINIMIZE SHOCK AND FIRE HAZARDS:

1. TURN OFF THE BOAT'S SHORE CONNECTION SWITCH BEFORE CONNECTING OR DISCONNECTING SHORE CABLE.
2. CONNECT SHORE POWER CABLE AT THE BOAT FIRST.
3. IF POLARITY WARNING INDICATOR IS ACTIVATED, IMMEDIATELY DISCONNECT CABLE.
4. DISCONNECT SHORE POWER CABLE AT SHORE OUTLET FIRST.
5. CLOSE SHORE POWER INLET COVER TIGHTLY.

DO NOT ALTER SHORE POWER CABLE CONNECTORS

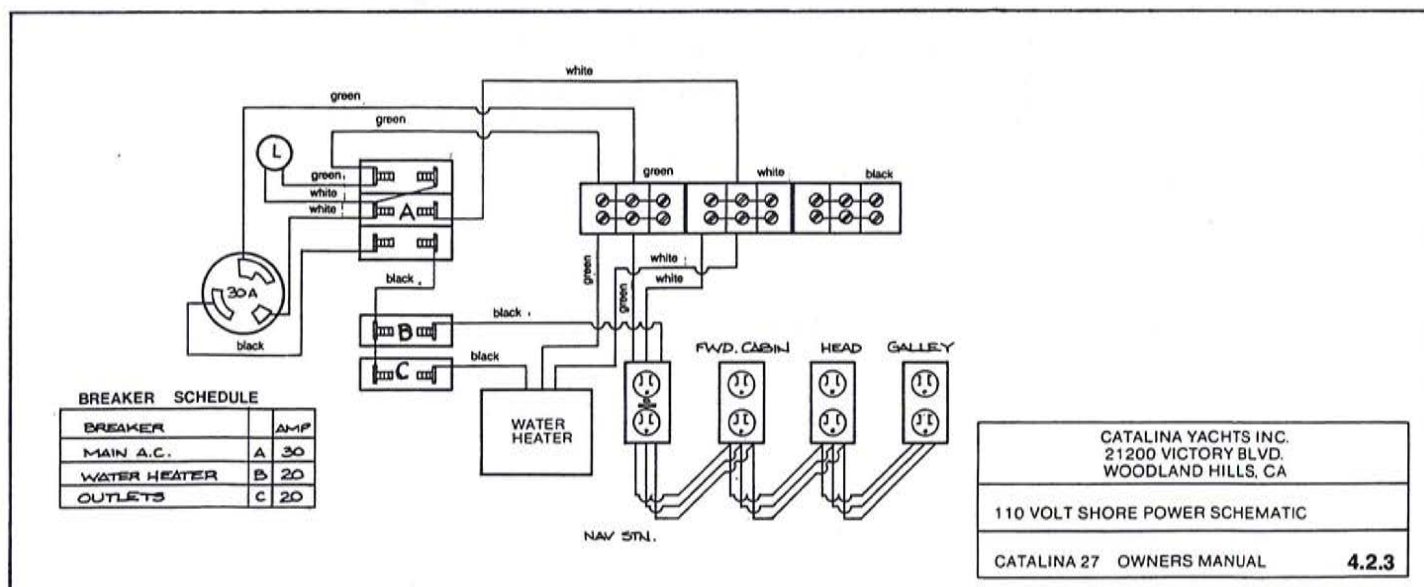



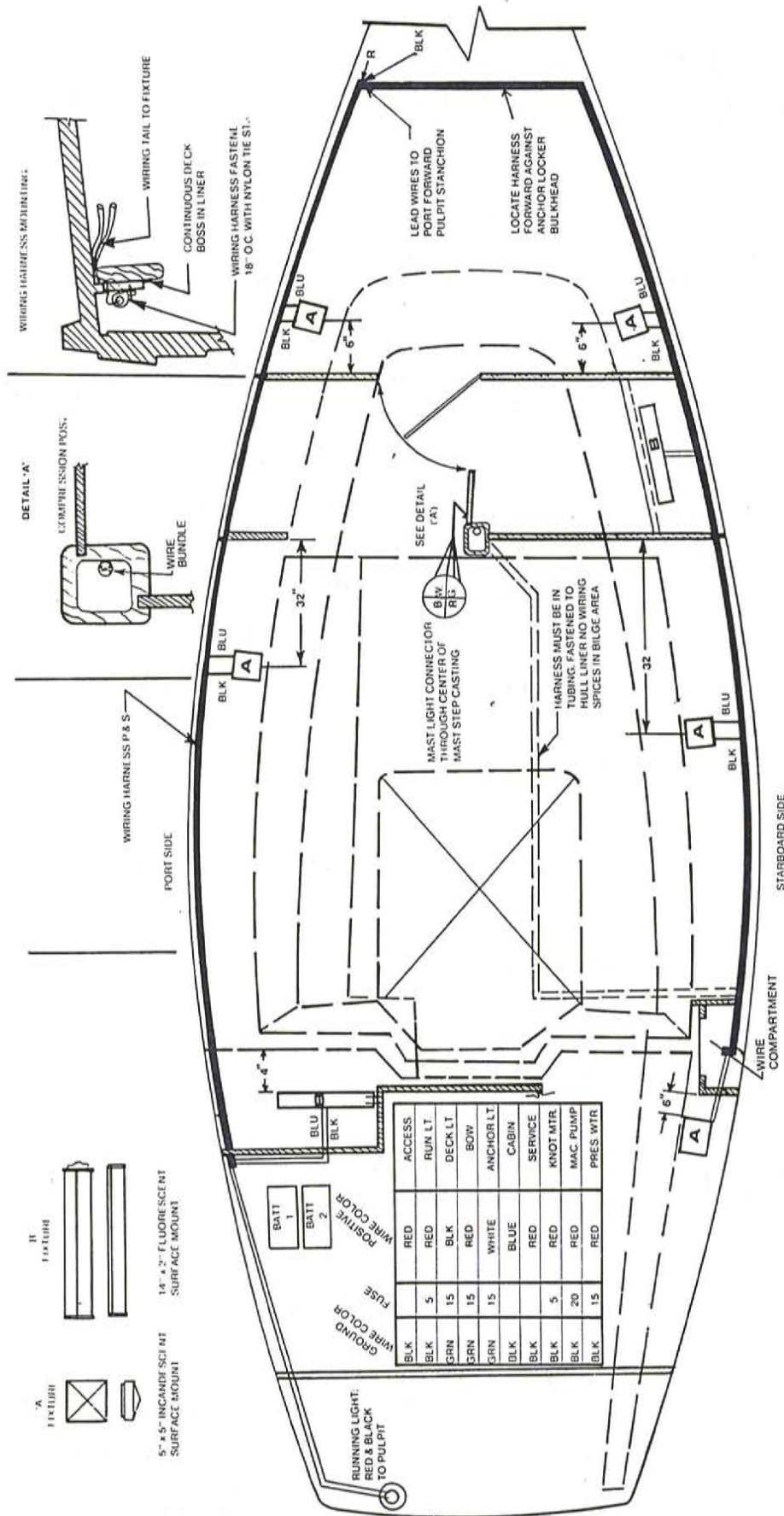

CATALINA YACHTS INC.  
 21200 VICTORY BLVD.  
 WOODLAND HILLS, CA

WIRING SCHEMATIC

CATALINA 27 OWNERS MANUAL

# STANDARD WATER SYSTEM

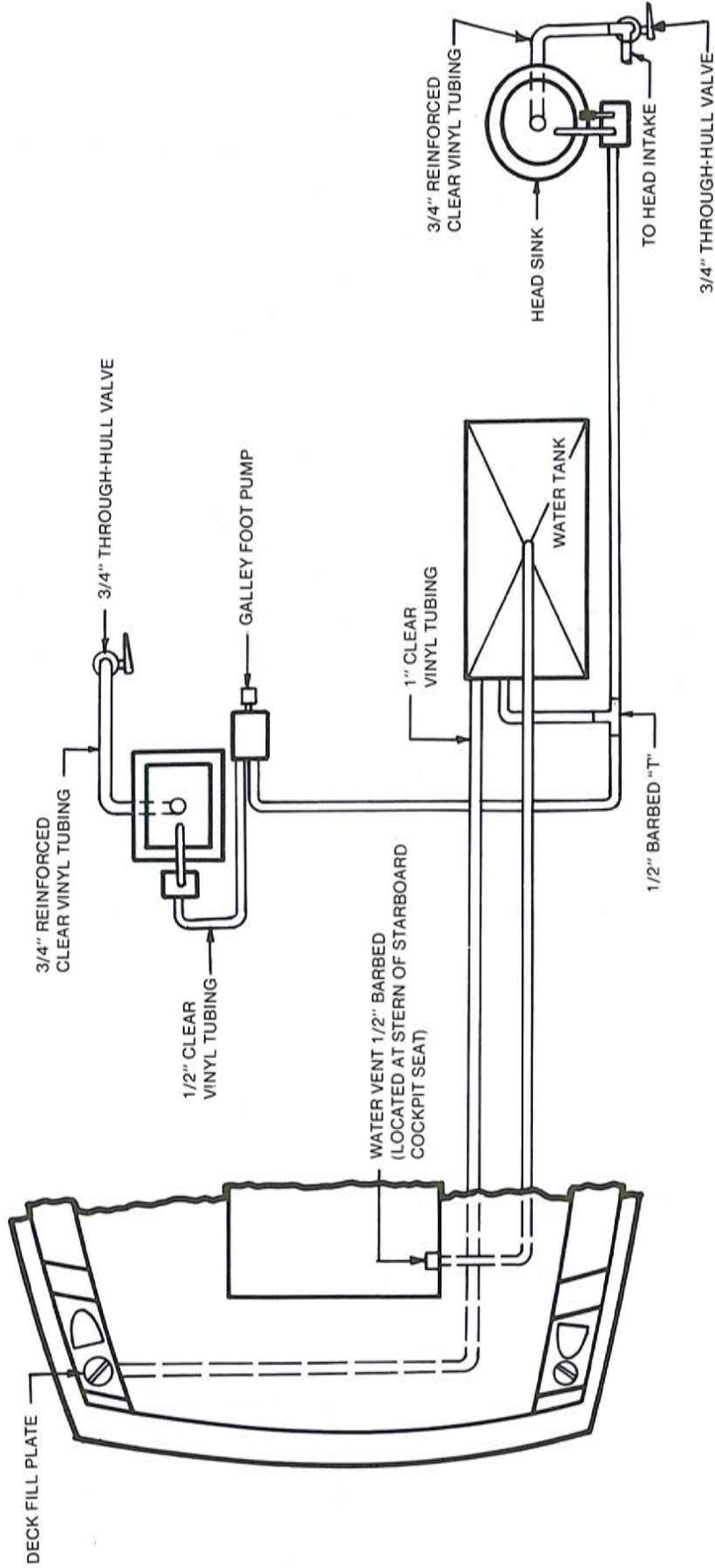

CATALINA YACHTS INC.  
 21200 VICTORY BLVD.  
 WOODLAND HILLS, CA

PLUMBING SCHEMATIC

CATALINA 27 OWNERS MANUAL

4.3.1

4.0 YACHT SYSTEMS CONT.

4.3 PLUMBING CONT.

4.3.2 MANUAL BILGE PUMP

THE MANUAL BILGE PUMP IS LOCATED IN THE LAZZARETTE LOCKER. THE HANDLE IS STORED IN A CLIP FITTING JUST ABOVE THE PUMP INSIDE THE LOCKER. INSERT THE HANDLE THROUGH THE WATER-TIGHT FITTING IN THE COCKPIT TO OPERATE THE PUMP.

THE PUMP INTAKE HOSE IS IN THE LOWEST POINT IN THE BILGE AT THE KEEL SUMP UNDER THE MAIN CABIN SOLE.

4.3.3 ELECTRIC BILGE PUMP

AN ELECTRIC BILGE PUMP IS STANDARD EQUIPMENT ON THE NEW CATALINA 27. THE PUMP IS LOCATED IN THE BILGE. THIS IS A SUBMERSABLE TYPE PUMP WITH AN AUTOMATIC FLOAT SWITCH WHICH ACTIVATES THE PUMP WHEN THE WATER LEVEL IN THE KEEL SUMP REACHES A DEPTH OF APPROXIMATELY 2". TO FUNCTION IN THE AUTOMATIC MODE THE TWO-POSITION SWITCH ON THE 12 VOLT MASTER PANEL MUST BE IN THE "AUTO" POSITION. THE BATTERY SELECT SWITCH MUST BE "ON" FOR THE PUMP TO OPERATE AUTOMATICALLY. THE PUMP CAN BE ACTIVATED MANUALLY BY TURNING THE BILGE PUMP SWITCH TO THE "ON" POSITION. SEE FIGURE FOR THE BILGE PUMP WIRING DIAGRAM. THE DISCHARGE FOR THE BILGE PUMP IS LOCATED ON THE TRANSOM.

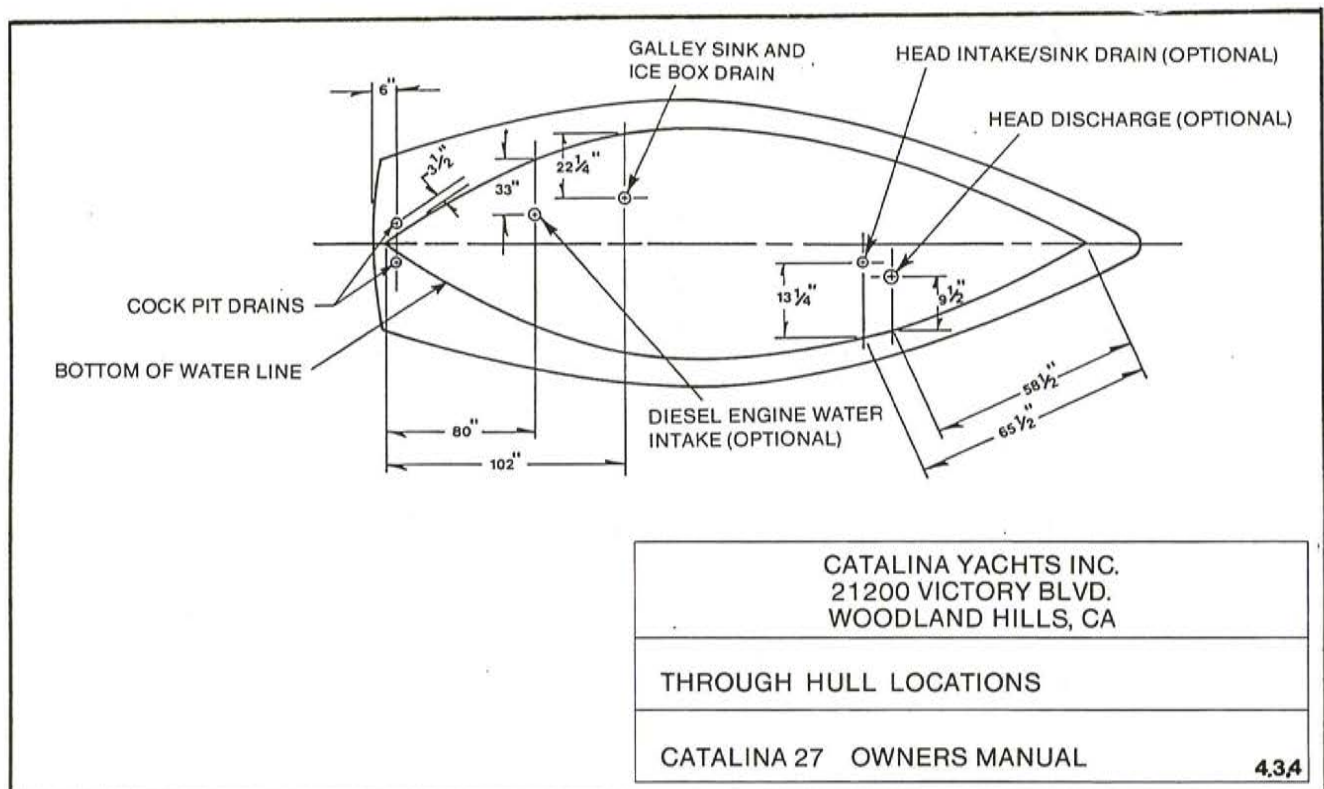



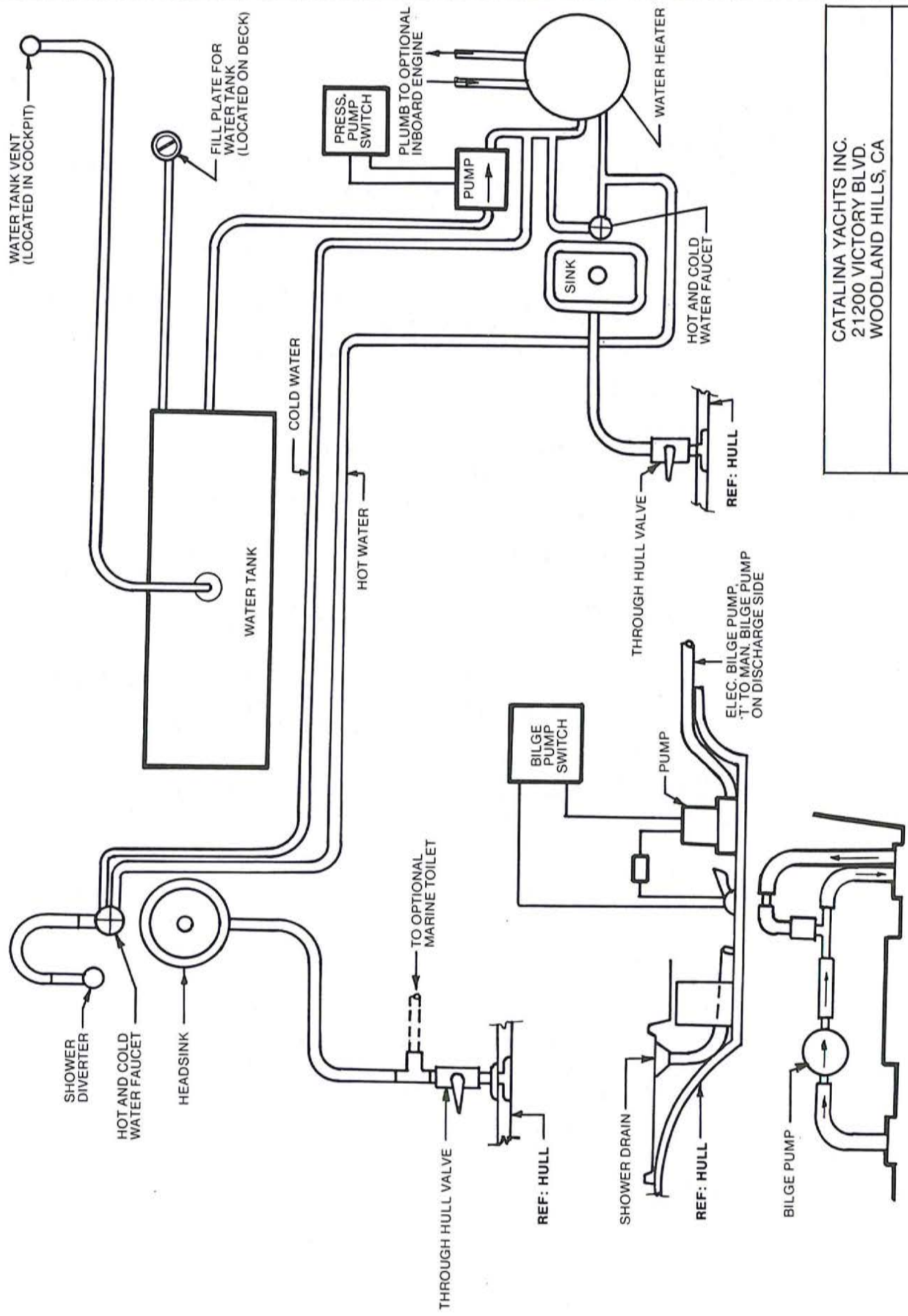

CATALINA YACHTS INC.  
 21200 VICTORY BLVD.  
 WOODLAND HILLS, CA

HOT AND COLD PRESSURE WATER SYSTEM

CATALINA 27 OWNERS MANUAL

4.3.5

4.0 YACHT SYSTEMS CONT.

4.3 PLUMBING CONT.

4.3.6 SEACOCKS

ALL UNDERWATER THROUGH HULL FITTINGS ARE EQUIPPED WITH SEACOCK VALVES. IT IS GOOD PRACTICE TO CLOSE ALL SEACOCKS WHEN LEAVING THE BOAT, ESPECIALLY FOR LONG PERIODS OF TIME.

TO CLOSE SEACOCKS, TURN CLOCKWISE 1/4 TURN: TO OPEN, TURN COUNTER-CLOCKWISE 1/4 TURN.

IT IS GOOD PRACTICE TO OPERATE THE SEACOCKS AT LEAST ONCE A MONTH TO KEEP THEM IN GOOD WORKING ORDER. THE HEAD INLET SEACOCKS MUST BE CLOSED AFTER EACH TIME THE HEAD IS USED.

4.3.7 MARINE TOILET OPERATION

USING THE HEAD

1. READ THE INSTRUCTIONS FOR OPERATION OF THE TOILET, AS SUPPLIED BY THE TOILET MANUFACTURER. THESE INSTRUCTIONS ARE ALSO PRINTED ON THE TOILET PUMP HOUSING. BE SURE EVERYONE WHO WILL BE USING THE HEAD IS FAMILIAR WITH THESE INSTRUCTIONS.
2. IMMEDIATELY BEFORE USING THE HEAD, THE INLET VALVE "A" MUST BE OPENED. THIS PROVIDES FLUSHING WATER TO THE TOILET. THE VALVE SHOULD BE KEPT CLOSED WHEN THE HEAD IS NOT IN USE. THIS WILL PREVENT WATER FROM FLOODING THE BOAT IF THE VALVE IN THE TOILET PUMP SHOULD FAIL.
3. WASTE WILL BE PUMPED DIRECTLY INTO THE HOLDING TANK WHEN THE BOWL IS EMPTIED. A MINIMUM AMOUNT OF WATER FOR EVERY FLUSH SHOULD BE USED IN ORDER TO TAKE BEST ADVANTAGE OF THE TANK'S CAPACITY BETWEEN PUMP-OUTS.

EMPTYING THE TANK THROUGH THE DECK DISCHARGE PLATE

1. THE HOLDING TANK SHOULD BE EMPTIED VIA THE DECK DISCHARGE PLATE ONLY AT APPROVED SHORE-BASED PUMP-OUT STATIONS.
2. REMOVE THE CAP FROM THE DECK DISCHARGE PLATE. THE THREADS ON THE PLATE CAP SHOULD BE PERIODICALLY COATED WITH SILICONE SPRAY OR PETROLEUM JELLY TO INSURE A GOOD SEAL AND PREVENT SEIZING.
3. THE PUMP-OUT STATION SUCTION HOSE SHOULD FORM A SEAL AT THE DECK PLATE.
4. BE SURE INLET VALVE "A" IS CLOSED WHEN THE TANK IS BEING EMPTIED.
5. AFTER THE TANK IS EMPTY, YOU MAY WISH TO OPEN VALVE "A" AND PUMP SOME WATER THROUGH THE TOILET AND INTO THE TANK TO DILUTE RESIDUAL SLUDGE AND RINSE THE TANK AND LINES.
6. CLOSE ALL VALVES AFTER THE TANK IS EMPTIED, AND RECAP THE DECK PLATE.

EMPTYING THE TANK USING THE MACERATOR PUMP

1. READ THE MACERATOR PUMP OPERATING INSTRUCTIONS SUPPLIED BY THE PUMP MANUFACTURER BEFORE PROCEEDING.
2. CLOSE THE INLET VALVE "A".
3. OPEN THE THROUGH HULL VALVE "B".
4. TURN ON THE PUMP WITH THE SWITCH ON THE 12 VOLT PANEL.



4.0 YACHT SYSTEMS CONT.

4.3 PLUMBING CONT.

4.3.7 MARINE TOILET OPERATION CONT.

5. THE PUMP WILL CHANGE TONE AFTER IT BECOMES PRIMED. IT WILL RESUME THE HIGHER PITCHED TONE AFTER THE TANK IS EMPTIED.
6. YOU MAY WISH TO RINSE THE TANK, HOSE LINES AND MACERATOR PUMP BY PUMPING CLEAR WATER THROUGH THE HEAD, THEN REPEATING THE PROCEDURE FOR EMPTYING THE TANK.
7. CLOSE VALVE "B" IMMEDIATELY AFTER EMPTYING THE HOLDING TANK TO PREVENT THE HOLDING TANK FROM FILLING WITH SEA WATER.

4.3.8 MACERATOR PUMP TROUBLESHOOTING

PROBLEM 1: THE MACERATOR PUMP MOTOR STARTS, THEN STOPS.

- A. CHECK THE FUSE: IT SHOULD BE 20 AMP.
- B. CHECK THE VALVES: "B" VALVE MUST BE OPEN.
- C. CHECK THE VENT LINE: IF THE BOAT HAS BEEN SAILED AT EXTREME ANGLES OF HEEL, FLUID MAY BE CLOGGING THE VENT LINE. DISCONNECT THE VENT AT THE TANK AND EMPTY THE HOSE INTO A DISPOSABLE CONTAINER.
- D. SLUDGE MAY HAVE FORMED IN BOTTOM OF THE TANK. THIS SHOULD BE DILUTED AS MUCH AS POSSIBLE. THE TANK SHOULD BE EMPTIED REGULARLY TO PREVENT SLUDGE BUILD-UP.

PROBLEM 2: THE HEAD TOILET PUMP HAS EXCESSIVE BACK PRESSURE, AND WILL NOT EVACUATE THE BOWL.

- A. REFER TO THE TOILET MANUFACTURER'S SPECIFICATIONS AND OPERATION INSTRUCTIONS.
- B. CHECK THE INLET VALVE "A", IT SHOULD BE OPEN.
- C. THE TANK MAY BE FULL. CHECK BY TAPPING TOP OF THE HOLDING TANK, EMPTY IF REQUIRED.
- D. THE VENT LINE FROM THE HOLDING TANK MAY BE KINKED, CLOGGED, OR FULL OF WASTE. EMPTY TANK IF REQUIRED.

PROBLEM 3: MACERATOR PUMP, WHEN ON, MAKES A HIGH-PITCHED SOUND, BUT DOES NOT EMPTY THE TANK.

- A. IMPELLER IN MACERATOR PUMP MAY BE FAULTY AND SHOULD BE REPLACED.
- B. THE VENT IS CLOGGED AND PUMP CANNOT PULL A PRIME AGAINST THE VACUUM IN THE TANK.
- C. THE HOSE INTO THE PUMP MAY BE CLOGGED.
- D. THE PUMP MAY BE DRAWING AIR THROUGH THE DECK PLATE, PREVENTING A PRIME. CHECK SEAL AT DECK PLATE MARKED "WASTE", AND LUBRICATE THREADS.
- E. VALVE "B" MUST BE OPEN WHEN EMPTYING THE TANK.



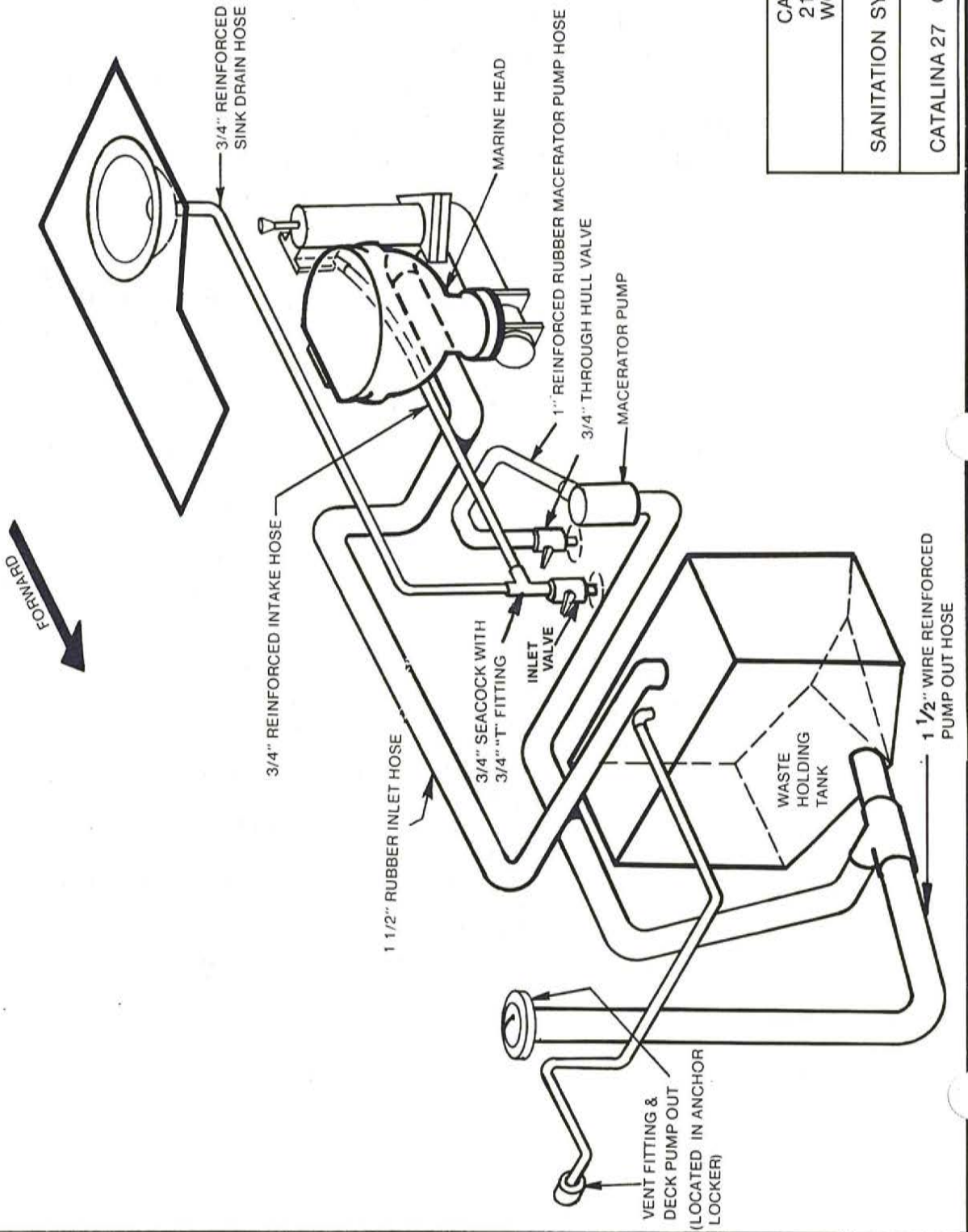

CATALINA YACHTS INC.  
 21200 VICTORY BLVD.  
 WOODLAND HILLS, CA

SANITATION SYSTEM PLUMBING

CATALINA 27 OWNERS MANUAL

4.3.9

## 4.0 YACHT SYSTEMS CONT.

### 4.4 AUXILIARY POWER

#### 4.4.1 GENERAL ENGINE INFORMATION

FOR A COMPLETE DESCRIPTION OF YOUR ENGINE, PLEASE CONSULT THE MANUAL SUPPLIED BY THE ENGINE MANUFACTURER. THIS CAN BE FOUND IN THIS BINDER.

TWO POINTS ARE WORTH SPECIAL ATTENTION: FIRSTLY, MARINE ENGINES WORK UNDER CONDITIONS TOUGHER THAN THOSE CONDITIONS OF AUTOMOTIVE ENGINES. YOUR MARINE ENGINE FACES CONSTANT TORQUING NOT ENCOUNTERED IN AUTOMOTIVE TYPE ENGINES. FOR THIS REASON, YOU MUST CHANGE YOUR ENGINE'S CRANK CASE OIL AS RECOMMENDED IN THE ENGINE MANUFACTURER'S GUIDE. BEFORE USING YOUR ENGINE, THE SHAFT COUPLING MUST BE DIMPLED FOR THE SET SCREWS THROUGH THE COUPLING INTO THE SHAFT ADJUSTED WITHIN A TOLERANCE OF .003 T.I.R. AFTER LAUNCHING. THIS IS DONE DURING COMMISSIONING OF THE YACHT. BE SURE THAT YOUR DEALER HAS MADE THIS ADJUSTMENT BEFORE USING YOUR ENGINE.

CHANGE THE OIL REGULARLY. KEEP SPARE FILTERS AND ALTERNATOR BELTS ON HAND, AND USE ONLY 2/3 TO 3/4 THROTTLE ON LONG PASSAGES. KEEP YOUR FUEL TANK FULL, WHENEVER POSSIBLE, TO PREVENT WATER CONDENSATION IN YOUR FUEL TANK.

TO RETARD ELECTROLYSIS, IN SALT OR BRACKISH WATER, WE RECOMMEND INSTALLING A ZINC COLLAR, IMMEDIATELY, ON THE PROPELLER SHAFT.

THE TACHOMETER ON THE ENGINE PANEL MAY REQUIRE CALIBRATION FOR AN ACCURATE READING.

#### 4.4.2 OUTBOARD RECOMMENDATIONS

THE MANUFACTURER RECOMMENDS AN OUTBOARD ENGINE IN THE 6 TO 9½ HORSE-POWER RANGE. ENGINES LARGER THAN THIS WILL NOT DRIVE THE BOAT FASTER THAN ITS CRITICAL HULL SPEED, AND GASOLINE ECONOMY WILL BE POOR.

THE FACTORY INSTALLED OUTBOARD BRACKET IS SPRING LOADED TO ASSIST LIFTING AND LOWERING THE ENGINE. IT LOCKS IN BOTH THE UP AND DOWN POSITIONS. TO RELEASE THE LOCK IN EITHER POSITION, A DOWNWARD PRESSURE IS APPLIED TO THE RED HANDLE WHILE LIFTING OR LOWERING THE ENGINE. THE MOTOR SHOULD NOT BE LIFTED CLEAR OF THE WATER WHILE IT IS RUNNING.

THE MOTOR BRACKET MANUFACTURERS RECOMMEND THAT AN 18 H.P. MAXIMUM ENGINE SHOULD NOT BE EXCEEDED.

THE OUTBOARD ENGINE MAY BE LEFT INSTALLED IN THE TRANSOM INDEFINITELY, IF THE OUTBOARD WILL RAISE SUFFICIENTLY HIGH TO PREVENT THE PROPELLER SHAFT FROM DRAGGING IN THE WATER. IT IS SUGGESTED THAT SOME DEVICE BE ARRANGED TO LOCK THE ENGINE TO THE BOAT TO PREVENT THEFT. BE SURE TO FOLLOW ALL DIRECTIONS WHICH ACCOMPANY YOUR OUTBOARD ENGINE AS TO SERVICING, GAS TO OIL MIXING RATIOS, FLUSHING PROCEDURES, ETC.



#### 4.0 YACHT SYSTEMS CONT.

#### 4.4 AUXILIARY POWER CONT.

##### 4.4.3 SHAFT PACKING GLAND (STUFFING BOX)

THE PACKING GLAND IS LOCATED AFT OF THE ENGINE, WHERE THE ENGINE SHAFT EXITS THE HULL.

A PROPERLY ADJUSTED SHAFT PACKING GLAND SHOULD DRIP SLIGHTLY (FROM 4 TO 10 PER MINUTE) WITH THE ENGINE OFF. TOO LOOSE AN ADJUSTMENT WILL ALLOW TOO MUCH WATER IN THE BILGE; AND ENGINE OPERATION WILL SPRAY WATER FROM THE SHAFT. TOO TIGHT AN ADJUSTMENT WILL ROB THE ENGINE OF POWER, AND LACK OF WATER LUBRICATION IN THE PACKING GLAND CAN GENERATE ENOUGH HEAT TO DAMAGE THE GLAND AND/OR SCORE THE PROPELLER SHAFT.

##### ADJUSTMENT:

1. HOLDING THE PACKING NUT WITH ONE WRENCH, USE A SECOND WRENCH TO LOOSEN THE LOCK NUT. TURN LOCK NUT FAR ENOUGH TO KEEP IT FROM INTERFERING WITH THE NEXT ADJUSTMENT (2 OR 3 TURNS).
2. TIGHTEN THE PACKING NUT TO OBTAIN 4 TO 10 DROPS PER MINUTE. HAND TIGHTENING OF THE PACKING NUT IS OFTEN SUFFICIENT TO OBTAIN THIS ADJUSTMENT. IF THIS IS NOT THE CASE, AN ADDITIONAL 1/4 TO 1/2 TURN WITH A WRENCH SHOULD PRODUCE THE DESIRED RESULT.
3. HOLD THE PACKING NUT IN PLACE WITH ONE WRENCH. USE THE SECOND WRENCH TO BRING LOCKING NUT SECURELY AGAINST PACKING NUT. MAKE CERTAIN THE LOCKING NUT IS TIGHT. FAILURE TO DO THIS COULD ALLOW THE PACKING NUT TO BACK OFF WHEN ENGINE IS OPERATING.
4. OPERATE THE ENGINE AT SLOW SPEEDS IN FORWARD AND REVERSE, AND USE A LIGHT TO CHECK FOR EXCESSIVE WATER AT THE PACKING NUT. SHUT OFF THE ENGINE AND RE-CHECK PACKING FOR PROPER DRIP.

##### 4.4.4 SHAFT ALIGNMENT

FOR PROPER OPERATION OF THE ENGINE, PROPELLER SHAFT AND ENGINE MUST BE ALIGNED.

ALIGNMENT IS GAUGED AT THE ENGINE AND SHAFT COUPLING. ALIGNMENT PROCEDURES MUST BE DONE WITH THE BOAT IN THE WATER AFTER THE MAST IS ERECTED AND THE RIG IS TUNED.

1. PROPELLER SHAFT MUST BE DIMPLED (1/8" DEEP) FOR TWO (2) COUPLING SET SCREWS. SET SCREWS MUST BE SAFETY WIRED, USING THE STAINLESS STEEL WIRE PROVIDED, AS ILLUSTRATED. CHECK KEY IN KEY WAY, AS IT MUST BE IN PLACE BETWEEN SHAFT AND COUPLER.
2. REMOVE COUPLING FLANGE BOLTS AND CHECK PROPELLER SHAFT FOR CLEARANCE. ADJUST STUFFING BOX TO PREVENT EXCESSIVE SEEPAGE, YET ALLOW SHAFT TO SPIN FREELY.
3. SLIDE SHAFT AWAY FROM ENGINE, AND CHECK COUPLING MATING SURFACES. THESE MUST BE CLEAN.



4.0 YACHT SYSTEMS CONT.

4.4 AUXILIARY POWER CONT.

4.4.4 SHAFT ALIGNMENT CONT.

4. SLIDE SHAFT FORWARD TO CONNECT COUPLING SURFACES. PILOT ON TRANSMISSION FLANGE MUST ALIGN WITH RECESS IN SHAFT COUPLING FLANGE. THIS IS AN INDICATION OF CORRECT AXIAL ALIGNMENT.
5. WITH COUPLING FLANGES IN CONTACT, MEASURE GAP AROUND EDGE OF COUPLING FLANGES WITH .003 FEELER GAUGE. MAXIMUM ALLOWABLE GAP AT ANY POINT IS THREE THOUSANDTHS OF AN INCH. TAKE THIS MEASUREMENT SEVERAL TIMES...ROTATING SHAFT 1/4 TURN EACH TIME. ANY GAP IN EXCESS OF .003 MUST BE CORRECTED BY CHANGING THE ENGINE'S POSITION, ESPECIALLY FORE AFT/TILT.

FOR EXAMPLE: EXCESSIVE GAP AT THE BOTTOM OF THE COUPLING (SEE DRAWING) INDICATES ENGINE IS TILTED TOO FAR AFT (FRONT TOO HIGH). USING A 15/16 END WRENCH, LOOSEN LOCK NUTS ON FORWARD MOTOR MOUNT(S). LOWER FRONT OF ENGINE BY CLOCKWISE ROTATION OF MOTOR MOUNT NUTS. RE-MEASURE GAP AT COUPLING. A GAP AT THE TOP OF COUPLING WOULD REQUIRE THE EXACT REVERSE PROCEDURE.

6. PULL SHAFT BACKWARDS, AS IN STEP 3. AGAIN, SLIDE SHAFT FORWARD, RE-CHECKING AXIAL ALIGNMENT, AS IN STEP 4.
7. REPEAT STEPS 5 AND 6 UNTIL ALIGNMENT WITHIN TOLERANCE IS ACHIEVED.
8. TIGHTEN MOTOR MOUNT LOCK NUTS AND INSTALL COUPLING BOLTS.

NOTE: ALIGNMENT SHOULD BE CHECKED YEARLY, OR WHENEVER ANY EXCESS VIBRATION IS NOTICED. THE ALIGNMENT CAN ALSO BE AFFECTED BY CHANGES IN RIGGING TENSION.

REF: DRIVE FLANGE

IN CONTACT

COUPLING

DIMPLE SHAFT  
1/8" MINIMUM

KEY AND KEY WAY

PROPELLER SHAFT

REF: DRIVEN FLANGE

.003 MAX

TYPICAL FLANGE

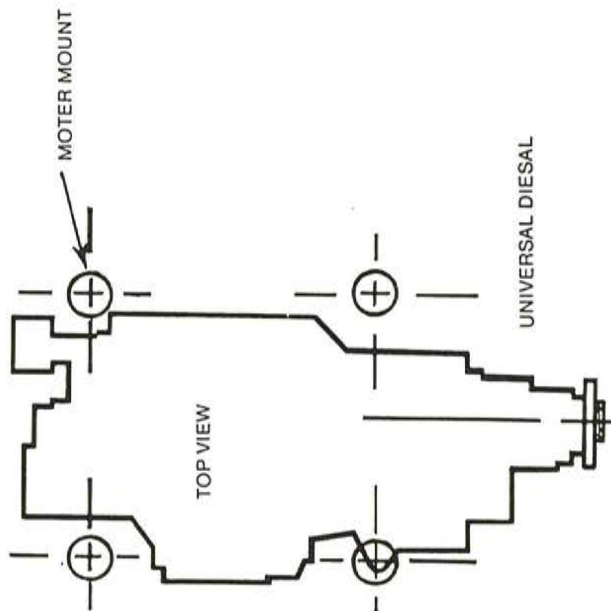

SAFETY WIRE  
THROUGH BOLT HEADS

FEELER GAUGE

.003

MEASURE GAP BETWEEN MATING FACES OF COUPLING FLANGES. MAXIMUM ALLOWABLE GAP AT ANY POINT IS .003 WHEN ANY POINT OF COUPLING FACES ARE IN CONTACT. TAKE THIS MEASUREMENT SEVERAL TIMES, ROTATING SHAFT 1/4 TURN EACH TIME. THIS MEASUREMENT MUST BE MADE WITH COUPLING BOLTS REMOVED.

CATALINA YACHTS INC.  
21200 VICTORY BLVD.  
WOODLAND HILLS, CA

SHAFT ALIGNMENT

CATALINA 27 OWNERS MANUAL

4.4.5

4.0 YACHT SYSTEMS CONT.

4.4 AUXILIARY POWER CONT.

4.4.6 FUELING

THE FUEL SYSTEM OF THE CATALINA 27 IS ILLUSTRATED AND CONSISTS OF A 15-GALLON ALUMINUM FUEL TANK, FUEL FEED AND RETURN LINES, FUEL FILTER ON ENGINE, AND ELECTRIC FUEL PUMP CONTROLLED BY THE ENGINE KEY SWITCH, A DECK FILL PLATE, AND AN OVERBOARD VENT THROUGH THE TRANSOM.

REFER TO THE UNIVERSAL ENGINE MANUAL PROVIDED FOR RECOMMENDED FUEL TYPE. A DIESEL ENGINE DOES NOT REQUIRE AN IGNITION SYSTEM. IT DEPENDS ON COMPRESSION AND THE CLEAN FUEL SUPPLIED TO THE ENGINE FOR IGNITION. SINCE THE CLOSE TOLERANCES REQUIRED BY THE ENGINE'S FUEL DELIVERY SYSTEM MAKE IT INTOLERANT OF DIRT OR WATER CONTAMINATION, THE ENGINE IS SUPPLIED WITH PRIMARY AND SECONDARY FILTERS WHICH PREVENT CONTAMINANTS FROM REACHING THE ENGINE WHERE THEY COULD CAUSE DAMAGE. HOWEVER, A CLOGGED FILTER, ALTHOUGH PROVIDING THIS PROTECTION, CAN ALSO STOP AN ENGINE. KEEPING THE FILTERS FREE OF DIRT AND WATER IS CRITICAL.

BEFORE FUELING:

1. EXTINGUISH ALL SMOKING MATERIALS AND CHECK THE FUELING AROUND THE AREA FOR OTHER SOURCES OF SPARK OR FLAME. REMOVE, IF FOUND.
2. SHUT OFF THE ENGINE AND ANY ELECTRICAL ACCESSORIES OR DEVICES.
3. DE-ENERGIZE ALL ELECTRICAL EQUIPMENT BY TURNING THE SELECTOR SWITCH TO THE "OFF" POSITION.
4. CLOSE ALL HATCHES AND PORTS.
5. ENSURE THAT A FIRE EXTINGUISHER IS READILY AVAILABLE.
6. ENSURE THAT THE PROPER (DIESEL, NOT GASOLINE) HOSE IS ABOUT TO BE USED.

WARNING:

DO NOT FUEL DURING AN ELECTRICAL STORM. BESIDES THE OBVIOUS HAZARD OF LIGHTNING, THE POSSIBILITY OF STATIC DISCHARGE IS GREATLY INCREASED AT THIS TIME.

FUELING PRODEURE:

1. REMOVE FILL PIPE COVER, USING THE PROPER TOOL.
2. PLACE NOZZLE OF FUEL HOSE IN THE FILL PIPE. KEEP THE NOZZLE IN CONTACT WITH THE DECK PLATE RIM DURING FUELING TO AVOID THE POSSIBILITY OF A STATIC SPARK.
3. FILL SLOWLY...DO NOT OVERFILL. IF IT IS NOT POSSIBLE TO SEE THE METER ON THE FUEL PUMP, THE ATTENDANT OR A CREW MEMBER SHOULD CALL OUT THE GALLONAGE FROM THE FUEL DOCK. FILLING THE TANK TO ONLY 95% CAPACITY WILL AVOID OVERFLOW PROBLEMS ON A HOT DAY.



4.0 YACHT SYSTEMS CONT.

4.4 AUXILIARY POWER CONT.

4.4.6 FUELING CONT.

4. REPLACE COVER, CLEAN UP ANY SPILLED FUEL. IF ANY RAGS, ETC., WERE USED FOR THIS PURPOSE, DISPOSE OF THEM ASHORE.
5. CHECK BELOW DECKS FOR PRESENCE OF FUMES OR FUEL LEAKAGE. CHECK BILGE, ENGINE SPACE AND MAIN CABIN. IF FUMES OR EVIDENCE OF LEAKAGE IS FOUND, DETERMINE THE CAUSE, CORRECT IT AND CLEAN UP ANY SPILLAGE BEFORE PROCEEDING.
6. OPEN ALL HATCHES AND PORTS TO VENTILATE THE BOAT.
7. SWITCH ON BATTERY.
8. THE ENGINE SHOULD BE STARTED ONLY WHEN IT IS CERTAIN THAT NO POTENTIALLY HAZARDOUS CONDITIONS EXIST.

4.4.7 FUEL SANITATION

BACTERIAL CONTAMINATION

BACTERIAL CONTAMINATION OF THE DIESEL FUEL CAN CAUSE PROBLEMS. THE BACTERIA NEED BOTH WATER AND FUEL TO EXIST, AND THRIVE AT THE FUEL/WATER INTERFACE IN A FUEL TANK. AS THEY MULTIPLY, THEY FORM MORE WATER AND FILTER-CLOGGING BROWN SLIME. THEIR PRESENCE WILL NOT BE KNOWN UNTIL ROUGH WEATHER CHURNS UP THE FUEL TANK, CAUSING CLOGGED FILTERS AT THE WORST POSSIBLE TIME.

KEEPING WATER OUT OF THE FUEL WILL PREVENT THE PROBLEM ENTIRELY. HOWEVER, A CERTAIN AMOUNT OF WATER DUE TO NORMAL CONDENSATION IN THE TANK IS TO BE EXPECTED.

FUEL ADDITIVES

FUEL ADDITIVES OR FUNGICIDES PROVIDE ANOTHER MEANS OF COMBATING CONTAMINATION. ADDITIVES BREAK DOWN THE WATER TO A MOLECULAR LEVEL, DISPERSING IT THROUGHOUT THE FUEL, ALLOWING IT TO PASS HARMLESSLY THROUGH THE FUEL SYSTEM. SEVERAL BRANDS OF THIS PRODUCT ARE AVAILABLE AT MARINE STORES.

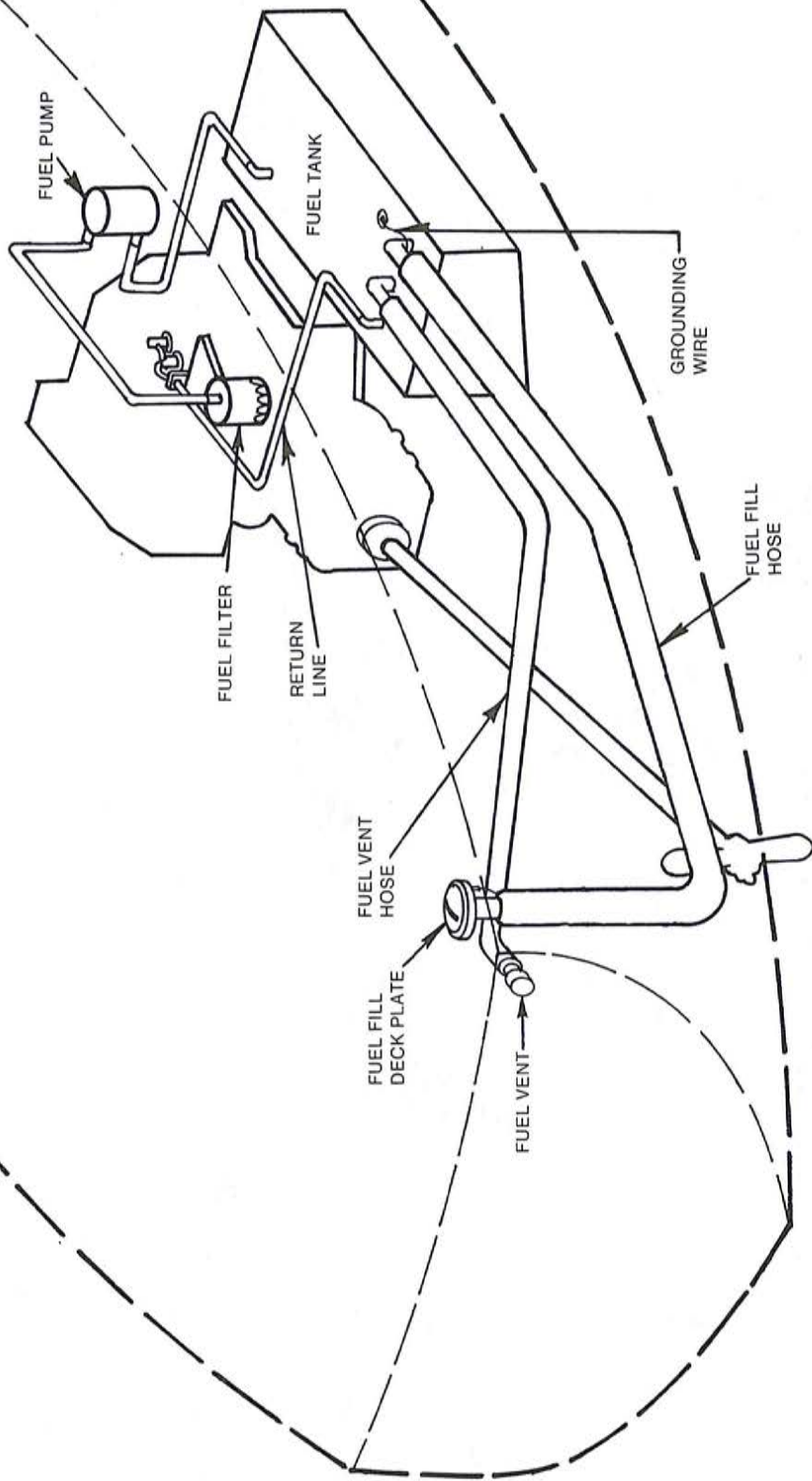

CATALINA YACHTS INC.  
 21200 VICTORY BLVD.  
 WOODLAND HILLS, CA

FUEL SYSTEM ILLUSTRATION

CATALINA 27 OWNERS MANUAL

4.4.8

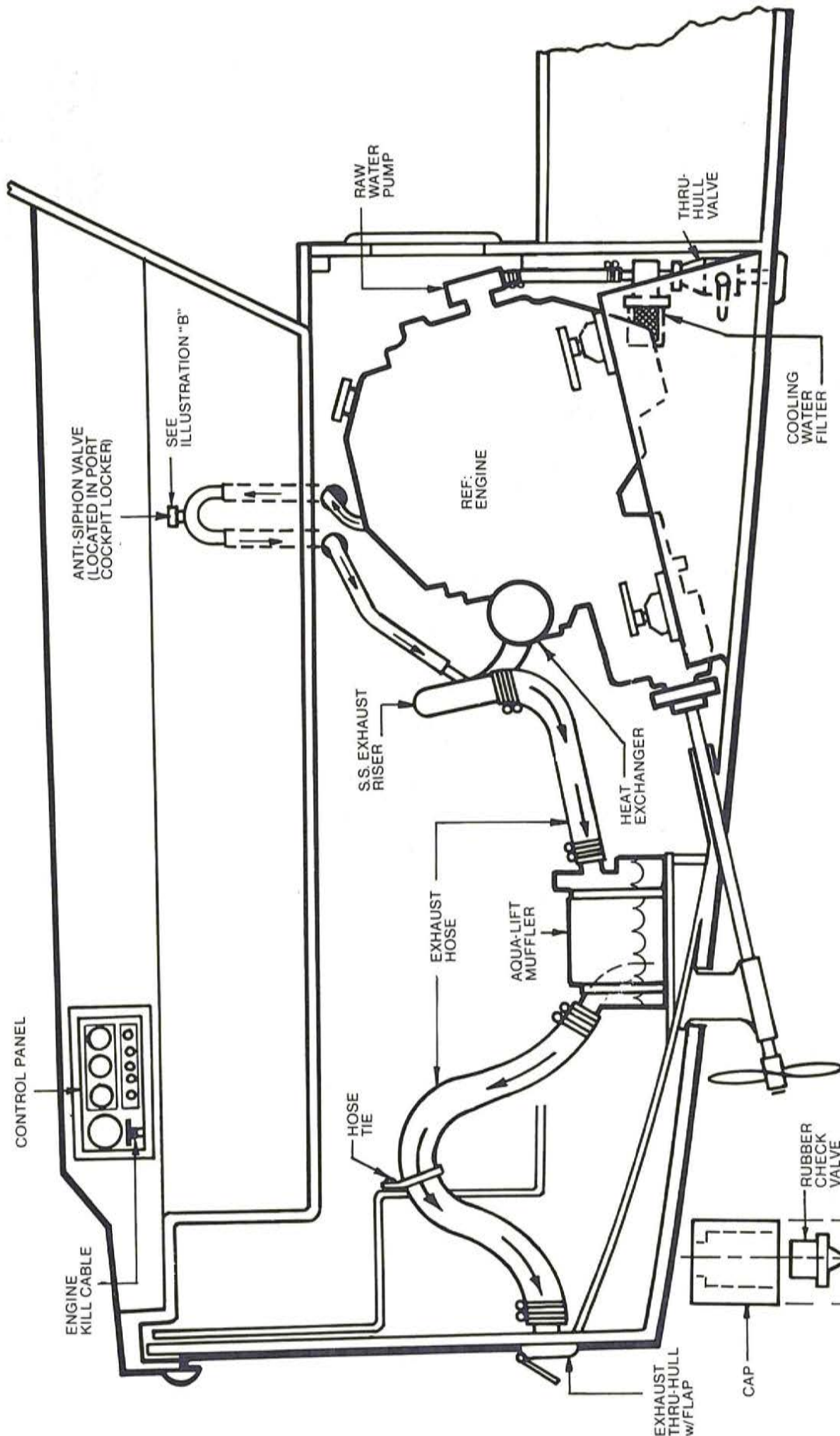

CATALINA YACHTS INC.  
 21200 VICTORY BLVD.  
 WOODLAND HILLS, CA

ENGINE EXHAUST SYSTEM ILLUSTRATION

CATALINA 27 OWNERS MANUAL 4.4.9.

**ILLUSTRATION B**  
 CROSS-SECTION OF  
 ANTI-SIPHON VALVE



4.0 YACHT SYSTEMS CONT.

4.4 AUXILIARY POWER CONT.

4.4.10 EXHAUST SYSTEM MAINTENANCE

IN-BOARD ENGINE INSTALLATIONS ON SAILBOATS DIFFER FROM ENGINE INSTALLATIONS ON POWER BOATS. THE PRIMARY DIFFERENCE IS THAT THE ENGINE IS USUALLY INSTALLED BELOW THE WATERLINE OF THE VESSEL.

THE BENEFIT OF THIS LOCATION IS THAT THE WEIGHT OF THE ENGINE IS WHERE IT WILL NOT ADVERSELY EFFECT TRIM, AND THAT THE SHAFT IS AT AN EFFICIENT ANGLE FOR POWERING AND MINIMUM DRAG WHEN SAILING.

ENGINE INSTALLATIONS BELOW THE WATERLINE REQUIRE SPECIAL ATTENTION TO THE DESIGN OF THE EXHAUST SYSTEM. THE DISCHARGED COOLING WATER MUST BE EXHAUSTED ABOVE THE WATERLINE TO AVOID EXCESSIVE BACK PRESSURE ON THE ENGINE AND PREVENT SEA WATER FROM TRAVELING UP THE EXHAUST LINE AND ENTERING THE ENGINE.

TO EXHAUST THE ENGINE ABOVE THE WATERLINE, THE DISCHARGED COOLING WATER AND EXHAUST GAS MUST BE "LIFTED" TO A LEVEL ABOVE THE THROUGH HULL FITTING ON THE TRANSOM.

IN THE CATALINA 27, THE EXHAUST COOLING WATER AND EXHAUST GAS ARE LIFTED ABOVE THE WATERLINE BY AN "AQUA-LIFT" TYPE MUFFLER. THE AQUALIFT MUFFLER PERFORMS THREE JOBS:

1. IT MIXES ENGINE GAS AND WATER TO COOL THE GAS AND LOWER EXHAUST LINE TEMPERATURE.
2. IT BAFFLES AND DEADENS ENGINE EXHAUST NOISE.
3. IT CREATES PRESSURE REQUIRED TO LIFT AND EXPEL COOLING WATER.

AS SHOWN IN ILLUSTRATION 4.4.9, THE INLET TUBE INTO THE AQUALIFT IS AT THE TOP OF THE TANK. THE OUTLET TUBE IS LONG AND NEAR THE BOTTOM OF THE TANK.

AS WATER ACCUMULATES IN THE BOTTOM OF THE TANK, EXHAUST GAS PRESSURE BUILDS IN THE TOP OF THE TANK. THIS FORCES THE COOLING WATER UP THE EXIT TUBE AND THROUGH EXHAUST LINE OVERBOARD.

THE SYSTEM REQUIRES EXHAUST PRESSURE IN THE TANK TO FUNCTION. WHEN THE STARTER MOTOR IS TURNING OVER, BEFORE THE ENGINE FIRES, WATER IS BEING PUMPED THROUGH THE COOLING SYSTEM BY THE BELT DRIVEN COOLING WATER PUMP. IT IS VERY IMPORTANT NOT TO OPERATE THE STARTER MOTOR FOR MORE THAN 30 SECONDS IF THE ENGINE DOES NOT FIRE. SHOULD IT BE NECESSARY TO OPERATE THE STARTER MOTOR MORE THAN 30 SECONDS, WATER MUST BE DRAINED FROM THE AQUALIFT BY REMOVING THE DRAIN SCREW AT THE BASE OF THE AQUALIFT.

THE DRAIN MAY BE OPENED UNTIL THE ENGINE FIRES, IF DESIRED. ALL CATALINA 27'S ARE EQUIPPED WITH ANTI-SYPHON VALVES AS AN ADDITIONAL PRECAUTION TO PREVENT COOLING WATER FROM ENTERING THE ENGINE.

REFER TO ITEM "B" OF ILLUSTRATION 4.4.9 THE FUNCTION OF THE ANTI-SYPHON VALVE IS TO PREVENT COOLING WATER FROM BEING SYPHONED THROUGH THE THROUGH HULL VALVE, THROUGH THE ENGINE COOLING SYSTEM AND INTO THE AQUALIFT MUFFLER WHEN THE ENGINE IS NOT OPERATING.

4.0 YACHT SYSTEMS CONT.

4.4 AUXILIARY POWER CONT.

4.4.10 EXHAUST SYSTEM MAINTENANCE CONT.

IF THE MUFFLER WERE TO FILL COMPLETELY WITH WATER, WATER WOULD TRAVEL UP THE INLET TUBE AND ENTER THE ENGINE BLOCK.

THE CATALINA 27 EXHAUST SYSTEM IS BASICALLY SIMPLE AND WILL PROVIDE TROUBLE FREE SERVICE IF YOU PERFORM REGULAR MAINTENANCE AND INSPECTION. THE IMPORTANT POINTS TO REMEMBER ARE:

1. CLOSE THE ENGINE COOLING WATER THROUGH HULL VALVE WHEN YOU ARE NOT OPERATING THE ENGINE.
2. DO NOT OPERATE THE STARTER MOTOR FOR MORE THAN 30 SECONDS WITHOUT DRAINING THE AQUALIFT MUFFLER.
3. PERIODICALLY DISASSEMBLE THE ANTI-SYPHON VALVE. BE SURE THE VALVE IS NOT FOULED WITH SALT DEPOSITS OR DEBRIS.
4. CHECK THE OPERATION BY REMOVING THE VALVE:
  - A. PUT A FINGER OVER ONE LARGE HOLE AND BLOW THROUGH THE OTHER. AIR SHOULD NOT ESCAPE THROUGH THE CAP.
  - B. IF YOU SUCK THROUGH ONE LARGE HOLE WITH A FINGER OVER THE OTHER, AIR SHOULD ENTER THE VALVE THROUGH THE GAP.
5. CHECK THE FLAPPER VALVE ON THE TRANSOM. THIS PREVENTS WATER FROM SURGING UP THE EXHAUST LINE IN A FOLLOWING SEA. REPLACE THE FLAP AS REQUIRED TO MAINTAIN FUNCTION.
6. REGULARLY INSPECT THE EXHAUST RISER FOR SIGNS OF DETERIORATION OR LEAKAGE. THE RISER IS BOLTED TO THE ENGINE AND FORMS A LOOP TO PREVENT WATER FROM BACKFLOWING INTO THE ENGINE. THE RISER IS SUBJECT TO CORROSION FROM THE EXHAUST GASES WHICH PASS THROUGH IT, AND FROM THE MOIST ATMOSPHERE OF THE BILGE. THE RISER SHOULD BE REPLACED AT THE FIRST SIGNS OF DETERIORATION OR AFTER A MAXIMUM OF FIVE YEARS SERVICE.

4.5 STEERING

4.5.1 EMERGENCY TILLER

IT IS RECOMMENDED THAT SKIPPER AND CREW BECOME FAMILIAR WITH THE EMERGENCY TILLER AND ITS USE.

THE EMERGENCY TILLER SHOULD BE STORED IN A CONVENIENT LOCATION KNOWN TO EVERYONE OPERATING THE BOAT.

A DRY RUN OF THE SYSTEM WILL MINIMIZE CONFUSION IN AN EMERGENCY:

1. LOCATE THE EMERGENCY TILLER.
2. REMOVE THE WHEEL; KEEPING A WRNCH HANDY FOR THIS PURPOSE IS A GOOD IDEA.
3. INSERT THE EMERGENCY STEERING TILLER IN THE RUDDER POST CAP.

NOTE

THE EMERGENCY TILLER MOVES THE WHOLE STEERING UNIT ASSEMBLY, INCLUDING CABLES AND QUADRANT. THESE ELEMENTS MUST BE FREE TO MOVE IN ORDER TO STEER THE BOAT.



## WARNING LABELS

THESE WARNING LABELS WERE APPLIED TO YOUR C-27 AT THE FACTORY, AND CONTAIN INFORMATION IMPORTANT FOR THE SAFE OPERATION OF YOUR BOAT. IF ANY OF THESE LABELS ARE MISSING, OR YOU REQUIRE REPLACEMENTS OR ADDITIONAL LABELS, PLEASE CONTACT THE CATALINA YACHTS PARTS DEPARTMENT, (818) 884-7700.

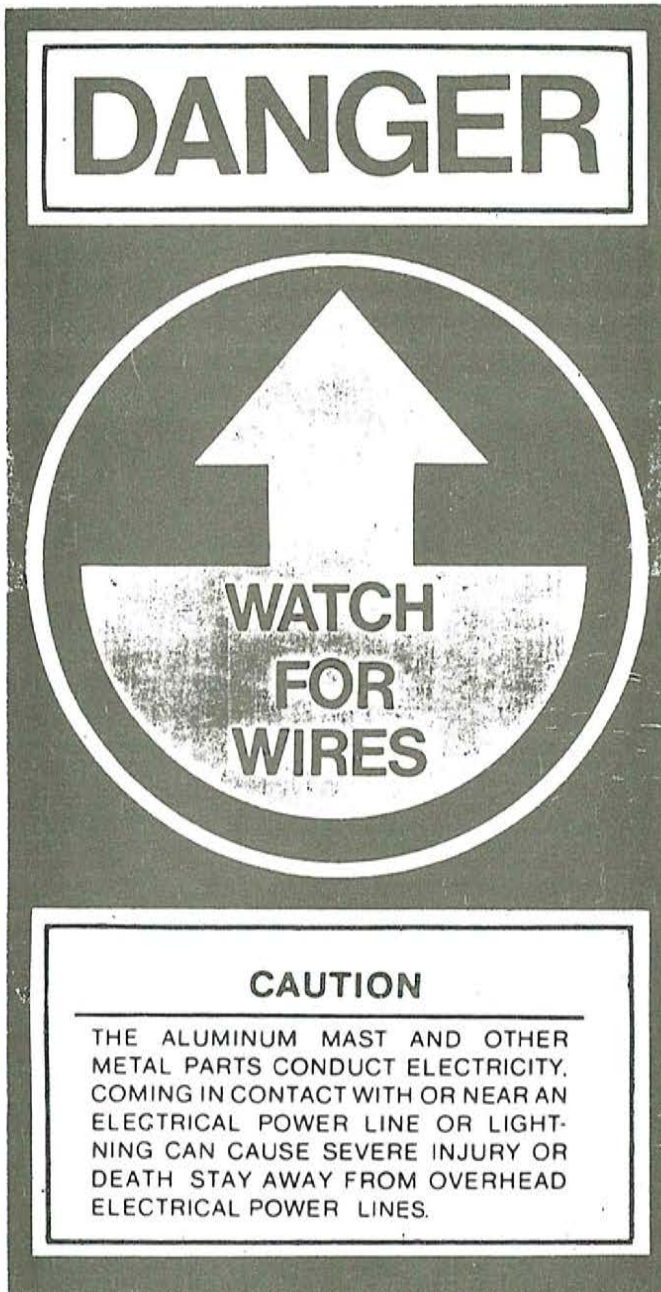

**PART # WS1**  
ON FORWARD SIDE OF MAST  
1'-0" FROM BOTTOM



**PART # WS2**  
BELOW ENGINE  
INSTRUMENT PANEL



**PART # WS3**  
ON ALL ENGINE ACCESS  
DOORS AND PANELS

**IMPORTANT! IF ENGINE FAILS TO START AFTER 30 SECONDS  
OF STARTER MOTOR OPERATION, WATER MUST BE DRAINED FROM AQUA-LIFT  
MUFFLER TO PREVENT SERIOUS DAMAGE TO ENGINE FROM COOLING WATER BACK-UP.**

**PART # WS4**  
BELOW ENGINE  
INSTRUMENT PANEL





6.0 OWNER-USER RESPONSIBILITY CONT.

6.2 REQUIRED SAFETY EQUIPMENT:

FIRE EXTINGUISHER(S)

IT IS WISE TO LOCATE A MINIMUM OF TWO, APPROVED FOR MARINE USE, FIRE EXTINGUISHERS...ONE FOR FORWARD OF THE GALLEY, AND ONE BEHIND THE GALLEY, PREFERABLY BELOW THE COCKPIT HATCH. SHOULD AN ALCOHOL STOVE OR ENGINE FIRE START, YOU CAN ALWAYS REACH A FIRE EXTINGUISHER. FOR EXAMPLE: YOU DO NOT WANT TO LOCATE BOTH EXTINGUISHERS IN THE HEAD AREA BECAUSE, IF YOU ARE LOCATED IN THE COCKPIT, YOU WOULD HAVE TO GET BY THE DANGER AREA TO REACH THEM IF THE FIRE IS EITHER IN THE GALLEY OR ENGINE AREA.

DRY CHEMICAL EXTINGUISHERS SHOULD BE INVERTED OCCASIONALLY TO PREVENT THE CONTENTS FROM PACKING. EXTINGUISHERS SHOULD BE RECHARGED YEARLY OR AFTER EACH USE, ACCORDING TO MANUFACTURER'S RECOMMENDATIONS.

LIFE VESTS

KEEP A COAST GUARD APPROVED LIFE VEST ON BOARD FOR EACH CREW MEMBER. WEAR THEM DURING ROUGH WEATHER AND NIGHT SAILING. CHILDREN SHOULD WEAR VESTS AT ALL TIMES, NO MATTER HOW MUCH THEY OBJECT.

HORN

YOUR YACHT SHOULD BE EQUIPPED WITH A HORN CAPABLE OF PRODUCING A BLAST THAT CAN BE HEARD FOR A DISTANCE OF ONE MILE.

FLARES

THE LAW REQUIRES THAT YOUR YACHT BE EQUIPPED WITH A MINIMUM OF THREE (3) DAY/NIGHT FLARES.

6.3 SUGGESTED SAFETY EQUIPMENT AND SAFETY PACKAGE:

MEDICAL KIT

A BASIC MEDICAL KIT IS A WISE INVESTMENT FOR ANY BOAT OWNER. SUGGESTED ITEMS INCLUDE: MOTION SICKNESS PILLS, ASPIRIN, BANDAGES, ETC. WE RECOMMEND THAT YOU PERSONALIZE YOUR MEDICAL SUPPLIES FOR YOURSELF AND YOUR CREW MEMBERS' SPECIFIC NEEDS. FIRST AID KITS ARE AVAILABLE AT MOST MARINE STORES. CONSULT YOUR PHYSICIAN FOR HIS RECOMMENDATIONS, IF YOU ARE PLANNING A VOYAGE AWAY FROM MEDICAL FACILITIES. A FIRST AID PROCEDURE BOOK IS A NECESSITY.

A VARIED ARRANGEMENT OF TOOLS IS, AGAIN, A WISE INVESTMENT TO HAVE ON YOUR BOAT. TAILOR YOUR TOOL BOX FOR THE CONDITIONS THAT YOU SAIL. FOR LOCAL SAILING, WITH PROFESSIONAL HELP JUST A PHONE CALL AWAY, YOU ONLY NEED A SMALL ARRAY OF TOOLS. HOWEVER, FOR LONG-RANGE CRUISING, A MORE EXTENSIVE SUPPLY OF TOOLS WILL BE NEEDED. YOUR MECHANIC MAY BE HELPFUL IN SUGGESTING TOOLS REQUIRED FOR YOUR PARTICULAR ENGINE INSTALLATION.

6.0 OWNER-USER RESPONSIBILITY CONT.

6.4 SAFETY PACKAGE, FACTORY OPTION:

<u>PACKAGE INCLUDES</u>	<u>DESCRIPTION</u>
1 EA	13-S ANCHOR
15 FT	5/16" GALVANIZED PC CHAIN
1 EA	1/2 X 200 ANCHOR LINE
2 EA	3/8" GALVANIZED SHACKLE
2 EA	6 1/2 X 23 FENDERS
14 FT	7/16" WHITE NYLON FENDER LINES (2 X 7)
1 EA	FOLDING ALUMINUM RADAR REFLECTOR
1 EA	FLARE KIT
1 EA	FREON AIR HORN
1 EA	BRASS BELL WITH BULKHEAD BRACKET
2 EA	FIRE EXTINGUISHER
1 PKG	BP-2 ALKALINE BATTERIES (D CELLS)
1 EA	CHAPMAN'S PILOTING, SEAMANSHIP, SMALL BOAT
6 EA	ADULT LIFE JACKETS
1 EA	FLASHLIGHT
1 EA	THROWABLE CUSHION
2 EA	1/2 X 20 DOCK LINES
1 EA	FIRST AID KIT

6.5 ANCHORS, ANCHORING AND MOORING

THE ANCHOR MANUFACTURER SUGGESTS AN ANCHOR IN THE 13 TO 16 POUND RANGE, TO BE USED AS A BOW ANCHOR IN ORDINARY CONDITIONS. THIS ANCHOR WILL ONLY BE EFFECTIVE WITH AT LEAST 6 FEET OF 1/4" OR HEAVIER GAUGE CHAIN, AND AT LEAST 7/16" OR HEAVIER NYLON LINE.

UNDER ADVERSE WEATHER CONDITIONS, AS MUCH AS A 25 POUND BOW ANCHOR COULD PROVE NECESSARY AND, POSSIBLY, A PLOUGH-TYPE ANCHOR MIGHT BE REQUIRED.

INQUIRE IN YOUR LOCAL AREA ABOUT ANCHORING PROCEDURES RELATIVE TO THE PLACE YOU PLAN TO VISIT. GET OPINIONS FROM SEVERAL EXPERIENCED PEOPLE, AND ALWAYS PLAY IT ON THE SAFE SIDE IN "MAKING UP" YOUR ANCHOR AS WELL AS IN USING IT. DO NOT FORGET TO WIRE ALL SHACKLE PINS SO THEY CANNOT COME LOOSE UNDER WATER.

REMEMBER: LIGHTER ANCHORS ARE MADE MORE EFFECTIVE BY INCREASING THE SCOPE: I.E., THE RATIO OF LENGTH OF LINE AND CHAIN TO DEPTH OF WATER. A 7:1 RATIO IS RECOMMENDED. THIS MEANS USING 7 FEET OF ANCHOR LINE FOR EACH FOOT IN WATER DEPTH.



6.0 OWNER-USER RESPONSIBILITY CONT.

6.6 LIGHTNING PRECAUTIONS

YOUR YACHT WAS NOT PROVIDED WITH A LIGHTNING PROTECTION SYSTEM DURING CONSTRUCTION. THE REASONS ARE AS FOLLOWS:

1. THERE IS NOT A PROCEDURE FOR LIGHTNING PROTECTION WHICH HAS PROVEN RELIABLE UNDER ALL CONDITIONS. YACHTS WITH ELABORATE LIGHTNING PROTECTION SYSTEMS HAVE SUSTAINED SERIOUS DAMAGE FROM A DIRECT LIGHTNING STRIKE.
2. IF THE BUILDER WERE TO ASSERT THAT THE YACHT WERE LIGHTNING PROTECTED, IT COULD INSTILL A FALSE SENSE OF SECURITY IN THE OWNER OR OPERATOR, LEADING TO LESS-THAN-PRUDENT ACTIONS WHEN LIGHTNING THREATENED.
3. LIGHTNING SYSTEMS ARE "OUT OF SIGHT, OUT OF MIND", EXCEPT WHEN LIGHTNING THREATENS. GENERALLY, THEY ARE NOT CHECKED AND MAINTAINED ON A REGULAR BASIS. A DEFECT IN THE SYSTEM (I.E., A BREAK IN A GROUND LINE) COULD - IN SOME CASES - INCREASE THE RISK OF PERSONAL HARM, AS WELL AS DAMAGE TO THE YACHT, AS COMPARED TO A YACHT WITH NO PROTECTION. THE REASON FOR THIS IS THAT MANY LIGHTNING PROTECTION SYSTEMS DISTRIBUTE THE HIGH VOLTAGE THROUGHOUT THE YACHT BEFORE ALLOWING IT TO EXIT THROUGH THE GROUND.
4. IT IS IMPOSSIBLE FOR CATALINA YACHTS TO CONTROL CHANGES WHICH YOU, THE OWNER, MAY MAKE TO THE YACHT, WHICH COULD EFFECT THE LIGHTNING PROTECTION SYSTEM.

YOU, THE OWNER, MUST DECIDE WHETHER OR NOT YOU WISH TO EQUIP YOUR YACHT WITH LIGHTNING PROTECTION AND, IF SO, THE METHOD OF DOING SO. FOR YOUR GUIDANCE, A COPY OF THE ABYC RECOMMENDATIONS IS ATTACHED. THE FOLLOWING SUGGESTIONS AND COMMENTS ARE ALSO OFFERED:

- A. KEEP THE SYSTEM AS SIMPLE AS POSSIBLE. THIS WILL FACILITATE BOTH INSTALLATION AND INSPECTION/MAINTENANCE. PERHAPS A SINGLE OVER-SIZE GROUND (BATTERY CABLE) FROM THE MAST BASE TO THE ENGINE, COUPLED WITH EXTERNAL SHROUD GROUNDS (SEE "B" BELOW) WILL MAXIMIZE RELIABILITY.
- B. ABYC RECOMMENDS STRAIGHT-LINE WIRE RUNS. THIS IS VIRTUALLY IMPOSSIBLE WITHIN THE YACHT. FOR GROUNDING THE SHROUDS: A BATTERY CABLE, WHICH CLIPS TO EACH SHROUD AND EXTENDS OUTSIDE THE YACHT TO THE WATER, CAN MINIMIZE THE NUMBER OF BENDS REQUIRED. THIS METHOD HAS THE ADDED ADVANTAGE OF KEEPING THE POWER SURGE OUTSIDE THE BOAT, AND ALLOWING EASY, ROUTINE INSPECTION. THE OBVIOUS DISADVANTAGE IS THAT THE CLIP ON CABLE IS NOT A PERMANENT INSTALLATION AND MAY NOT BE IN PLACE WHEN AN UNEXPECTED LIGHTNING STRIKE OCCURS.
- C. USE ONLY TOP QUALITY MATERIALS, AND GO OVERSIZE WHEREVER POSSIBLE.
- D. KEEP ALL PERMANENT ATTACHMENT POINTS AND CONNECTIONS WHERE THEY ARE READILY AVAILABLE FOR INSPECTION, YET PROTECTED FROM DAMAGE OR INADVERTENT DISCONNECTION.

6.0 OWNER-USER RESPONSIBILITY CONT.

6.6 LIGHTNING PRECAUTIONS CONT.

FACTORY INSTALLED METAL TANKS, 110 VOLT SYSTEMS AND MAJOR COMPONENTS ARE GROUNDED TO THE ENGINE. THE ENGINE IS GROUNDED VIA THE SHAFT AND PROPELLER TO THE WATER. THE PURPOSE OF INTERNAL GROUNDING IS FOR STATIC CHARGE CONTROL AND ACCIDENTAL SHORTS IN THE INTERNAL SYSTEMS -- NOT TO PROVIDE LIGHTNING PROTECTION. HOWEVER, YOU CAN INCORPORATE THE GROUND LINES PRESENT IN A LIGHTNING PROTECTION SYSTEM WHICH YOU MAY WISH TO ADD.

BY FAR, THE MOST IMPORTANT CONSIDERATION REGARDING LIGHTNING IS OBSERVING COMMON SENSE SAFETY PRECAUTIONS WHEN LIGHTNING THREATENS. THE KEY CONSIDERATIONS ARE LISTED IN THE AMERICAN BOAT AND YACHT COUNCIL (ABYC) PUBLICATION WHICH IS REPRINTED HEREIN, FOR YOUR REFERENCE.

5.0 DECOMMISSIONING CONT.

5.4.1 GENERAL NOTES

WE RECOMMEND THE FOLLOWING PROCEDURES BE FOLLOWED WHEN STORING THE YACHT FOR PROLONGED WINTER MONTHS. BEGIN BY CONSULTING YOUR AUTHORIZED DEALER ABOUT STORING THE BOAT IN OR OUT OF THE WATER IN FREEZING CLIMATES. IF AT ALL POSSIBLE, THE MANUFACTURER RECOMMENDS KEEPING THE YACHT IN DRY STORAGE FOR SEVERE WINTERS.

ALL THROUGH HULL FITTINGS SHOULD BE DRAINED AND CLOSED OFF. WATER IN THE SANITATION SYSTEM AND OTHER TANKS SHOULD BE PUMPED OUT. FILL THE LINES AND FITTINGS WITH ANTI-FREEZE TO PREVENT WATER FROM RUNNING IN, FREEZING AND EXPANDING, OR CRACKING THE LINES AND FITTINGS.

NOTE

ALWAYS CONSULT THE MANUFACTURER'S MANUAL FOR SPECIAL INSTRUCTIONS.

UNLESS THE MANUFACTURER'S MANUAL STATES OTHERWISE, DRAIN THE BLOCK, DISCONNECT THE WATER INTAKE HOSE FROM THE THROUGH HULL FITTINGS, ATTACH AN ADDITIONAL LENGTH OF HOSE AND PLACE THE END OF THIS HOSE IN A BUCKET OF ANTI-FREEZE. RUN THE ENGINE UNTIL STRAIGHT ANTI-FREEZE COMES OUT OF THE EXHAUST LINE. STOP THE ENGINE AT THIS POINT, PLUG OR CAP THE EXHAUST LINE AND REMOVE THE ADDITIONAL HOSE AND BUCKET.

OUTBOARD MOTORS SHOULD BE REMOVED, SERVICED AND STORED IN A WARM, DRY LOCATION UNTIL REINSTALLED WHEN COMMISSIONING.



## 6.0 OWNER - USER RESPONSIBILITY

### 6.1 GENERAL SAFETY TIPS

1. DO NOT VENTURE OUT WHEN THE WEATHER CONDITIONS ARE UNFAVORABLE, OR ARE PREDICTED TO BECOME SO. LISTEN TO WEATHER FORECASTS; CHECK WITH YOUR HARBOR PATROL OFFICE; LOOK OUT FOR SMALL CRAFT STORM WARNINGS.
2. BE ESPECIALLY CAREFUL IN AREAS WHERE THERE MAY BE COMMERCIAL SHIPPING TRAFFIC. KEEP WELL AWAY FROM SHIPPING CHANNELS. KEEP A SHARP LOOK-OUT WHEN CROSSING THE SHIPPING CHANNELS.
3. LEARN THE RULES OF THE ROAD. ALL OTHER SAILORS WILL EXPECT THAT YOU KNOW THEM AND ABIDE BY THEM. THE U.S. COAST GUARD (BBE-2) 400 S. ELEVENTH STREET S.W., WASHINGTON, D.C. 20590 WILL SUPPLY FREE LITERATURE ON THIS. YOUR LOCAL BRANCH OR HARBOR PATROL OFFICE MAY HAVE IT AVAILABLE.
4. IF YOUR BOAT HAS A GENOA SAIL WHICH OBSCURES THE HELMSMAN'S VISION, HAVE A DEPENDABLE PERSON IN THE CREW KEEP A SHARP LOOK-OUT UNDER THE JIB SAIL FOR ONCOMING TRAFFIC.
5. WHEN SAILING AT NIGHT, PROVIDE SAFETY HARNESSSES FOR YOURSELF AND YOUR CREW, AND TIE THESE LINES TO THE BOAT. USE APPROVED HARNESSSES.
6. PURCHASE ALL COAST GUARD REQUIRED SAFETY EQUIPMENT, AND LEARN HOW TO USE IT.
7. ENROLL IN A C.G. CLASS OR OTHER CERTIFIED BOATING AND SAILING CLASS. YOU WILL LEARN A LOT AND ENJOY SAILING EVEN MORE.
8. DO NOT TAKE MORE THAN A SAFE NUMBER OF PERSONS ABOARD YOUR BOAT WHEN SAILING.
9. MARINE INSURANCE IS WORTH EVERY PENNY YOU PAY FOR IT. TAKE OUT INSURANCE FROM THE START. SEE YOUR DEALER FOR A RECOMMENDED MARINE AGENT, IF YOU DO NOT HAVE ONE.
10. KEEP ALL SEAT HATCHES AND MAIN HATCH AND FORWARD HATCHES CLOSED DURING ROUGH WEATHER OR GUSTY WINDS WHICH COULD UNEXPECTEDLY STRIKE THE BOAT AND CAUSE A KNOCK-DOWN.
11. CAUTION! THE ALUMINUM MAST AND THE METAL PARTS CONDUCT ELECTRICITY. COMING IN CONTACT WITH OR APPROACHING AN ELECTRICAL POWER LINE CAN BE FATAL. STAY AWAY FROM OVERHEAD POWER LINES AND WIRES OF ANY KIND WHEN LAUNCHING, UNDERWAY OR STATIONARY.

## 5.0 DECOMMISSIONING

### 5.2 LAYING UP

IN COLD CLIMATES WHERE YACHTS ARE DECOMMISSIONED DURING THE WINTER, YOUR CATALINA 27 MAY BE SAFELY STORED IN THE WATER, PROVIDED ADEQUATE MEASURES ARE TAKEN TO PREVENT ICE DAMAGE TO THE HULL. CHECK WITH YOUR YARD TO DETERMINE THE FEASIBILITY OF STORING IN THE WATER.

WHEN THE BOAT IS TO BE STORED ON LAND, THE MAST MAY BE LEFT STEPPED ON THE DECK. HOWEVER, IT IS RECOMMENDED THAT THE MAST BE REMOVED AT THE TIME OF HAULING FOR A THOROUGH INSPECTION AND PREPARATION FOR NEXT SEASON. THIS ALLOWS PLENTY OF TIME TO ORDER AND REPLACE SHROUDS OR RIGGING PARTS NEEDED OVER THE WINTER MONTHS, AVOIDING ANY DELAYS IN THE SPRING COMMISSIONING.

FOLLOWING PROPER LAY-UP PROCEDURES WILL MINIMIZE THE EFFORT NEEDED TO RECOMMISSION IN THE SPRING.

### 5.3 BEFORE HAULING

1. REFER TO ENGINE MANUAL INSTRUCTIONS FOR WINTERIZING THE ENGINE. PERFORM THE APPROPRIATE IN-WATER STEPS.
2. CONSULT MANUFACTURER'S INSTRUCTIONS FOR WINTERIZING ANY OPTIONAL OR OWNER-INSTALLED EQUIPMENT.
3. INSPECT THE CRADLE ON WHICH THE BOAT WILL BE STORED. CHECK WELDS AND PADDED POPPITS FOR CONDITION AND REPAIR AS REQUIRED.
4. LIFT THE BOAT WITH STRAPS AT THE LOCATIONS ILLUSTRATED.

### 5.4 AFTER HAULING

1. WASH BOTTOM, REMOVING GROWTH AND LOOSE PAINT.
2. WASH TOPSIDES, DECK AND ALL OTHER EXTERIOR FIBERGLASS SURFACES. WAX ALL EXCEPT THE NON-SKID SURFACES.
3. REMOVE ALL SAILS. FOLLOW SAILMAKER'S INSTRUCTIONS (OR INSTRUCTIONS IN SECTION 3.7) WITH REGARD TO CLEANING. SCHEDULE ANY REPAIRS REQUIRED AND STORE IN A DRY PLACE.
4. REMOVE ALL SHEETS AND LINES, CLEAN AND STORE IN A DRY PLACE.
5. IF THE MAST HAS BEEN REMOVED FROM THE YACHT, REMOVE ALL STAYS AND SHROUDS FROM MAST. WASH THE ENTIRE STAY AND SHROUD ASSEMBLY, USING FRESH WATER AND A STIFF BRUSH. DRY THOROUGHLY AND COIL INTO LARGE, NON-KINKING COILS. STORE COILS IN A DRY PLACE. WASH AND WAX ALL SPARS. COIL HALYARDS INTO NON-KINKING COILS AND PUT IN A DARK-COLORED PLASTIC BAG TO PROTECT FROM SUNLIGHT, IF STORING OUTDOORS. LASH THEM TO THE MAST. STORE THE MAST EITHER INSIDE OR OUTSIDE WITH ADEQUATE SUPPORT ALONG ITS LENGTH.



5.0 DECOMMISSIONING CONT.

5.4 AFTER HAULING CONT.

6. IF MAST IS TO BE LEFT IN PLACE, REMOVE BOOM; CLEAN AND STORE AS DESCRIBED BEFORE. CLEAN SHROUD/STAY END FITTINGS, TOGGLES, ETC., USING FRESH WATER AND A STIFF BRUSH. APPLY A LIGHT COAT OF SILICONE GREASE, PAYING PARTICULAR ATTENTION TO THE END FITTINGS WHERE THEY CONNECT TO THE STAYS AND SHROUDS.
7. CLEAN AND LUBRICATE ALL DECK HARDWARE THAT CONTAIN MOVABLE PARTS. FOLLOW MANUFACTURER'S INSTRUCTIONS ON WINCHES.
8. REMOVE ALL GEAR SUCH AS BOOKS, DOCUMENTS, BEDDING, PFDs, ANYTHING MOVABLE THAT IS SUBJECT TO RUST, CORROSION OR MILDEW.
9. REMOVE ALL FOOD SUPPLIES FROM LOCKERS AND ICE CHEST. WASH OUT ICE CHEST INTERIOR WITH A WEAK SOLUTION OF CLOROX. LEAVE ICE CHEST LID OPEN.
10. STORED BATTERIES SHOULD BE FULLY CHARGED, AND BOTH POSITIVE AND NEGATIVE TERMINALS SHOULD BE DISCONNECTED. THE BATTERIES MAY BE EITHER LEFT ABOARD OR STORED IN A COOL, DRY PLACE. SUB-ZERO TEMPERATURES WILL NOT HARM A FULLY CHARGED BATTERY.
11. CLOSE ALL MANUAL SHUT-OFFS FOR THE STOVE FUEL SYSTEM.
12. WINTERIZE THE HEAD SYSTEM IN ACCORDANCE WITH MANUFACTURER'S INSTRUCTIONS.
13. DRAIN THE WATER HEATER IN ACCORDANCE WITH MANUFACTURER'S INSTRUCTIONS.
14. REMOVE ALL ELECTRONIC GEAR THAT MAY REQUIRE SERVICING DURING THE WINTER.
15. REMOVE FIRE EXTINGUISHERS FOR WEIGHING, CHECKING AND ANY NECESSARY RE-CHARGING. IF AN AUTOMATIC FIRE EXTINGUISHER SYSTEM IS INSTALLED, RETURN THE CYLINDERS TO THE YACHT AND REINSTALL AS SOON AS POSSIBLE.
16. IF CUSHIONS ARE LEFT ABOARD, BRING COCKPIT CUSHIONS BELOW AND PLACE ALL CUSHIONS ON EDGE TO ENCOURAGE VENTILATION.
17. LEAVE ALL INTERIOR LOCKERS OPEN TO ENCOURAGE VENTILATION.
18. ENSURE THAT COCKPIT AND DECK SCUPPERS ARE OPEN AND FREE.
19. IF THE BOAT IS TO BE COVERED, ENSURE THAT THE COVER IS INSTALLED IN SUCH A WAY AS TO PROVIDE ADEQUATE VENTILATION, AND THAT THE COVER IS NOT PERMITTED TO CHAFE AGAINST THE HULL OR DECK.
20. IF THE BOAT IS NOT TO BE COVERED, ENSURE THAT MECHANISMS SUCH AS WINCHES AND STEERING PEDESTALS ARE PROVIDED WITH ADEQUATE COVERS.
21. IF THE MAST IS TO REMAIN STEPPED, SNUB ALL SHROUDS AND HALYARDS TO MINIMIZE NOISE, WEAR AND CHAFE.



4.0 YACHT SYSTEMS CONT.

4.7 ACCOMMODATION

4.7.2 GALLEY STOVE

THERE IS PROVISION FOR A GIMBALLED STOVE WITH OVEN ON THE PORT SIDE OF THE GALLEY AREA. A TWO-BURNER ALCOHOL STOVE IS FACTORY STANDARD INSTALLATION. IT COMES WITH AN OPERATION AND MAINTENANCE BOOKLET PROVIDED BY THE STOVE MANUFACTURER. A C.N.G. STOVE IS AVAILABLE AS A FACTORY OPTION. FOLLOW THE INSTRUCTIONS FOR OPERATION CAREFULLY WHEN USING THE STOVE. ALTHOUGH COMPRESSED NATURAL GAS IS AMONG THE SAFEST OF COOKING FUELS, EXTREME CAUTION SHOULD BE USED WHEN COOKING ABOARD, OR HANDLING C.N.G. FUEL TANKS.

IMPORTANT

WHEN FILLING AND LIGHTING THE STOVE, PLEASE OBSERVE THE MANUFACTURER'S INSTRUCTIONS. IT IS GOOD PRACTICE TO HAVE A FIRE EXTINGUISHER WITHIN SAFE REACH OF THE GALLEY. ALCOHOL FIRES CAN BE EXTINGUISHED WITH WATER SO IT IS WISE TO KEEP A FILLED BUCKET OR CONTAINER WITHIN REACH OF THE COOK.

ALL MEASUREMENTS ARE APPROXIMATE

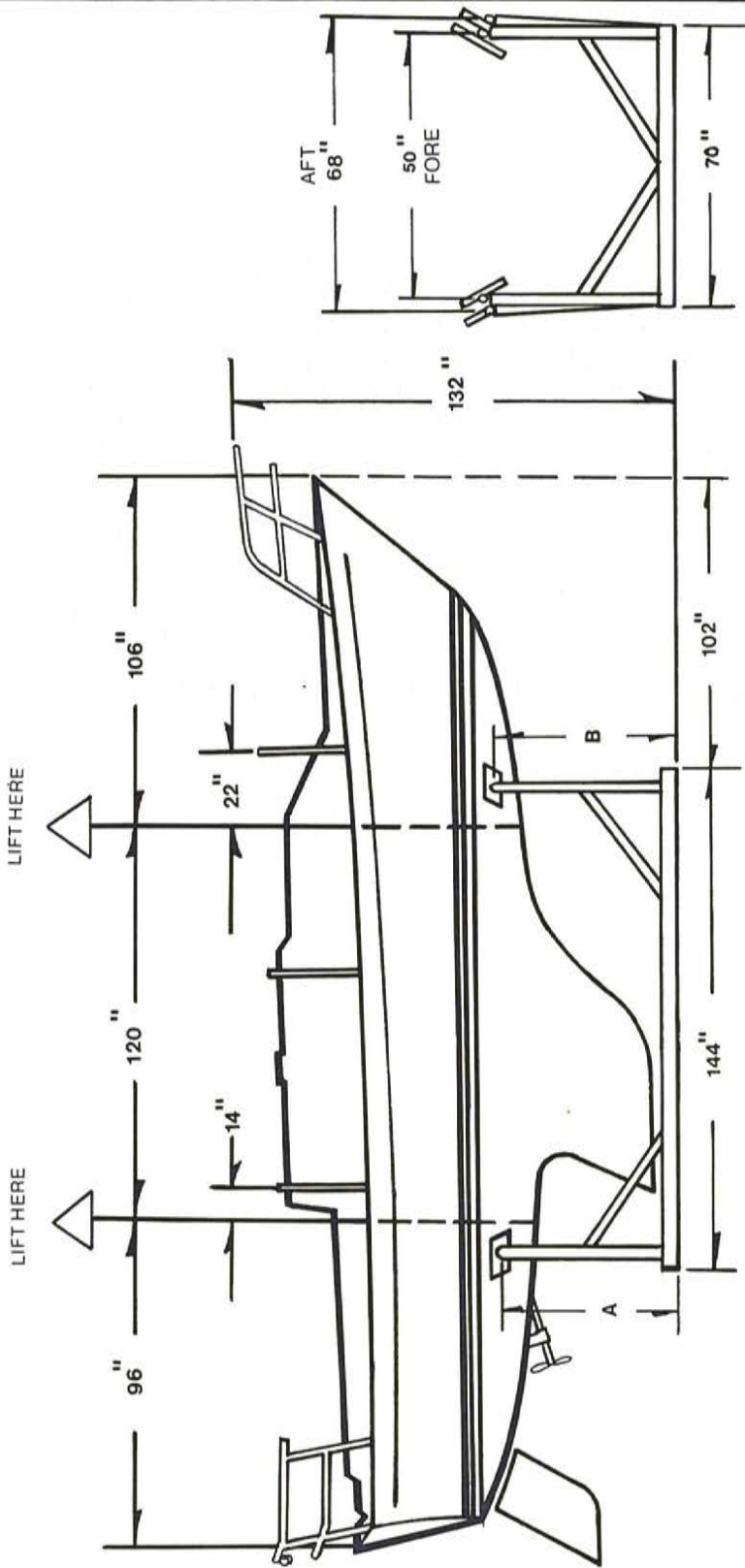

A	38"	B	42"
WING	45"	FIN	46"

CATALINA YACHTS INC.  
 21200 VICTORY BLVD.  
 WOODLAND HILLS, CA

DIMENSIONS FOR LIFTING PROCEDURE

CATALINA 27 OWNERS MANUAL

### STANDARD EQUIPMENT

1. 1"x8" 0" GENOA "T" TRACK (1) P&S
2. BOW PLATE W/ANCHOR ROLLER
3. 3/8" LOWER CHAINPLATE "U" BOLTS (2), S.S. P&S
4. UPPER CHAINPLATE, (1), S.S. 1 3/4"x1/4" P&S
5. 1 1/2" I.D. FUEL FILL DECK PLATE (GAS)
6. BOW PULPIT S.S. (DOUBLE RAIL 14/COMB. RUN. LIGHT)
7. 2 1/2" LIFELINE STANCHION (3) P&S
8. STERN PULPIT S.S. (DOUBLE RAIL WESTERN LIGHT)
9. ANCHOR LOCKER (FIBERGLASS)
10. FORWARD HATCH, ALUM FRAMED, TRAPIZODIAL
11. SEA HOOD FOR MAIN HATCH, FIBERGLASS
12. MAIN HATCH COVER, FIBERGLASS
13. COCKPIT SEAT LOCKER (1) FIBERGLASS P&S
14. LAZARETTE SEAT LOCKER, FIBERGLASS
15. MAST STEP, ALUM
16. WINDOW FIXED (2) P&S
17. 6" HANDRAIL, TEAK P&S

18. 6" MOORING CLEAT (2) P&S
19. 3" I.D. WATER FILL PLATE
20. 3" I.D. HOLDING TANK PUMP-OUT PLATE
21. 110 VOLT DOCKSIDE POWER OUTLET
22. ENGINE CONTROL PANEL W/F.G. PAN
23. ENGINE CONTROLS (GAS, DIESEL, TILLER STEERING ONLY)
24. 3" I.D. FUEL TANK VENTS S.S. (1) P&S
25. DOUBLE BLOCK DECK ORGANIZER (1) P&S
26. MAINSHEET WINCH #16, SELF TAILING
27. HALYARD WINCH #7
28. HORSE BLOCK, MOLDED FIBERGLASS
29. MIDSHIP TRAVELER TRACK, ALUM, 54" A. ROLLER TRAVELER CAR ALUM. B. TRAVELER ADJUSTER (1) P&S
30. BILGE PUMP
31. COAMING COMPARTMENT (1) P&S
32. WATER TANK VENT 1/2", BARBED FACING DOWN
33. OPENING PORT, ALUM FRAMED (1) P&S
34. SINGLE SHEET STOPPER (1) P&S

35. 1 1/2" COCKPIT SCUPPER (1) P&S
36. TEAK STEP PAD
37. JIB SHEET WINCH, LEWMAR #30 (1) PS&
38. JIB SHEET CLEAT (1) P&S (DELETE IF SELF-TAIL WINCHES ARE USED)
39. SINGLE BACKSTAY TANG, S.S.
40. 6" MOORING CLEAT (2) P&S

### OPTIONAL EQUIPMENT

1. SPLIT BACKSTAY TANK P&S
2. PEDESTAL STEERING W/GUARD 24" DIAM.
3. JIB WINCHES, LEWMAR #40, SELF TAILING
4. DOUBLE SHEET STOPPER W/SECOND JIB HALYARD
5. 1 1/2" I.D. FUEL FILL DECK PLATE (DIESEL)

### CRUISING SPINNAKER GEAR (OPTIONAL)

1. FOREGUY CAM CLEAT W/FAIRLEAD
2. BULLSEYE FAIRLEAD FOR FOREGUY, (3) REQ'D.

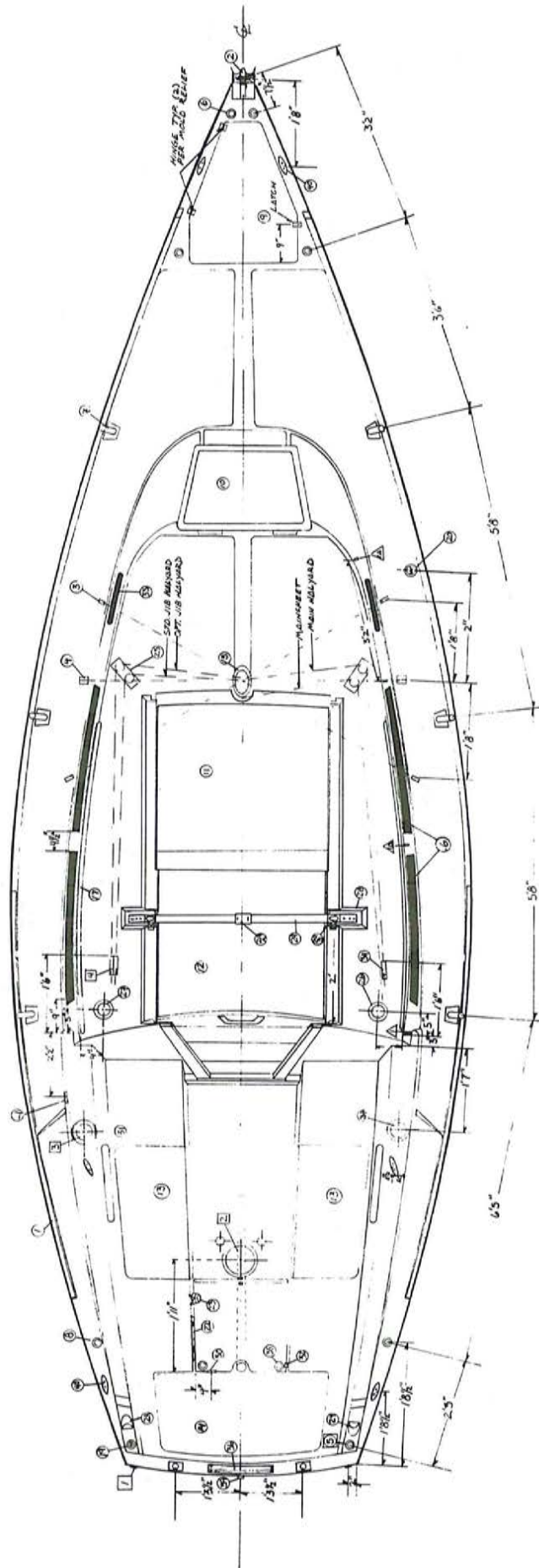

CATALINA YACHTS INC.  
21200 VICTORY BLVD.  
WOODLAND HILLS, CA

DECK HARDWARE ARRANGEMENT PLAN

CATALINA 27 OWNERS MANUAL 4.6.1



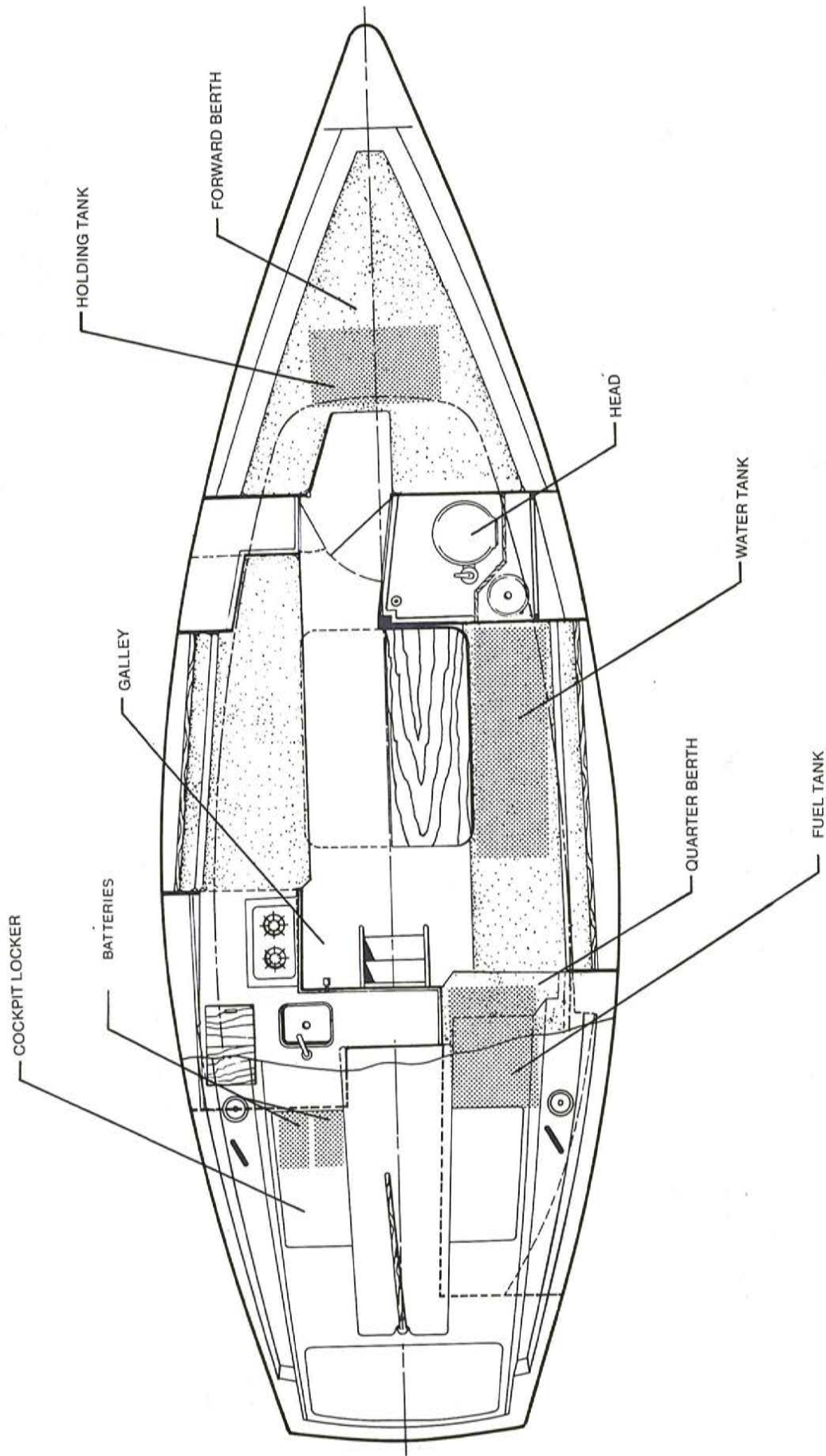

CATALINA YACHTS, INC.  
 21200 VICTORY BLVD.  
 WOODLAND HILLS, CA

CABIN ARRANGEMENT

CATALINA 27 OWNERS MANUAL

4.7.1

## CATALINA 27 AND 30

REGOMMENDED MAINTENANCE SCHEDULE AND INSPECTION GUIDELINE LISTI EACH TIME THE BOAT IS USEDA. RIGGING

1. Inspect turnbuckle lock nuts, tighten if necessary.
2. Inspect clevis pins and cotter pins.
3. Visually inspect spreader tips and other areas where sails may chafe during sailing, replace tape as necessary.
4. Halyards free and not tangled

B. HULL AND DECK INSPECTION

1. Tiller moves freely, Pedestal steering, ok.
2. Bilges and compartments are dry.
3. Thru hull valves, hoses and clamps., ok
4. Check running lights, ok.

C. ENGINE

1. Check engine oil and fuel levels
2. Packing gland ok, cooling water intake valve opens and closes ok
3. Choke, throttle, clutch work ok.
4. Blower System, ok
5. Check Bilge areas for fuel fumes before starting engine

II ONCE A MONTH CHECK - DURING SEASON:A. RIGGING

1. Inspect chain plates, fastenings, and bolts, tighten as necessary
2. Inspect blocks, shackles, cotter pins.
3. Check rigging tune, rigging wire condition.
4. Check turnbuckles, and locking pins.

B. HULL AND DECK

1. Check cockpit drains, Clear of debris
2. Inspect thru hull valves, open and close freely.
3. Winches turn freely, Lubricate as per manufactures recommendations
4. Clean and oil exterior teak as necessary
5. Clean and wax gel coat surfaces as necessary.

C. ENGINE

1. Check oil and fluid levels
2. Battery, Check fluid levels and tie downs
3. Tighten all bolts and nuts to proper torque
4. Check fuel tank, fittings and hose clamps.

### III AT LEAST ONCE A SEASON

#### A. RIGGING INSPECTION

1. Mast head pins and sheaves. Turn freely.
2. Halyards and nicropress fittings, good condition, taped
3. Spreaders tips and bases, check all mast fittings.
4. All shroud terminations and swedged fittings.
5. Gooseneck assembly and boom assembly.
6. Mast, boom and spreaders cleaned and waxed.

#### B. HULL, DECK, AND CABIN

1. All chainplates and thru bolts tight
2. Disassemble winches and lubricate bearings and pawls.
3. Electrical system and battery tie downs, coat to prevent corrosion, and terminal connectors.
4. Drain and flush fresh water system.
5. Check head and anti-siphon valve ( in toilet)
6. Hatch gaskets and hold down dogs.
7. Bottom, keel and rudder condition
8. Lifelines, stanchions, and pelican hooks.

#### C. ENGINE

1. Check shaft alignment, re-pack stuffing box, if necessary.
2. Clean motor thoroughly.
3. Inspect fuel system
4. Tune engine as per manufactures recommendation