

WASSNER



INSTALLATION MANUAL

AND

OWNER'S MANUAL

NOVEMBER 1987

HOOD SEAFURL 705/810/915 LD

HOOD LIMITED WARRANTY FOR SEA FURL/GEMINI PRODUCTS

I. **WARRANTY:** Hood Yacht Systems warrants that Hood Sea Furl and Gemini headstay products will be free from defects in material and workmanship for a period of five years. That period shall commence upon receipt of the Hood warranty registration card within 30 days upon receipt of the goods. Any part which proves defective in normal usage during the five year period will be repaired or replaced by Hood Yacht Systems.

This Warranty is subject to the following conditions and limitations:

- A. Hood Yacht Systems liability shall be limited to repair or replacement, at Hood Yacht Systems discretion, of goods or parts defective in materials or workmanship. This shall be the buyer's exclusive remedy.
 - B. Except where otherwise specified, quality shall be in accordance with Hood Yacht Systems specifications.
 - C. The Hood Sea Furl and Gemini must be installed and maintained properly and used under normal conditions in the application for which they were intended.
 - D. This warranty does not apply to any products that were improperly installed or maintained, or subject to misuse or negligence during normal operation and storage.
 - E. Hood Yacht Systems shall not be responsible for shipping charges or installation labor associated with any warranty claims.
 - F. Terms of this limited warranty shall be one year if the product is used in commercial, rental or charter operations as well as with respect to any swaged attachments to wire or rod, either standing or running rigging.
- II. Failure to obtain an owner's manual or otherwise be aware of the information contained in the owner's manual may void this warranty.
- III. The limited warranty is in lieu of all other warranties; any implied warranties are limited in duration to the duration of the warranty stated here.
- IV. Hood is not responsible for consequential damages of any sort, to the extent that such exclusion is permitted by applicable law.

705/810/915

READ THIS PAGE

To insure continued satisfaction and trouble-free operation it is necessary to follow the simple guidelines listed below.

1. Rinse the bearings regularly with fresh water.
2. Watch for halyard wrap. Look up!
3. If it jams - find out why - don't force it!
4. Treat this unit like any other equipment - inspect it regularly.
5. If any problem persists, call your dealer.

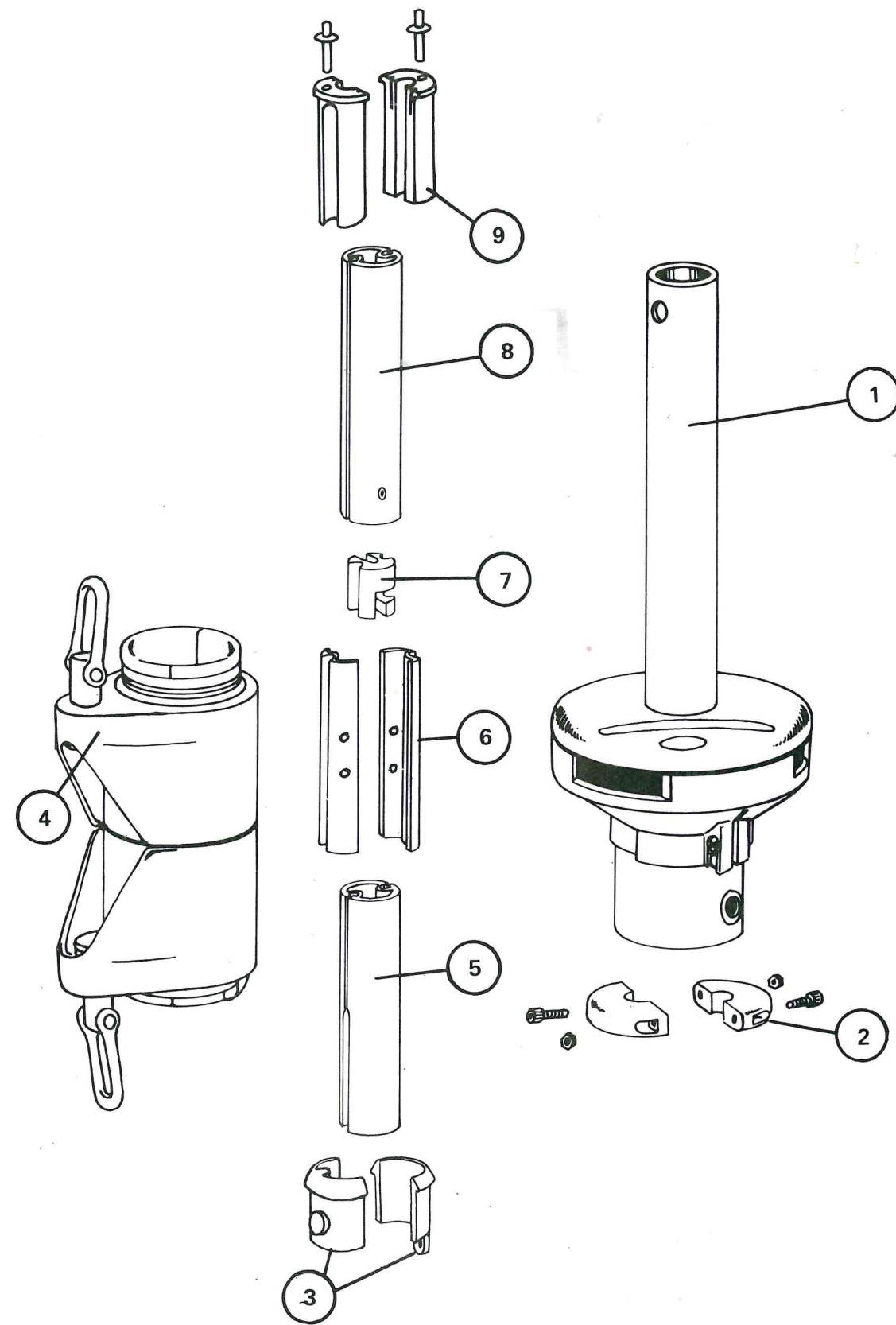

Figure 1.

CUSTOMER CHECK LIST

REFERENCE #	DESCRIPTION	QUANTITY
<input type="checkbox"/> 1	Drive Unit Assembly	1
<input type="checkbox"/> 2	Centering Clamp Assembly	1
<input type="checkbox"/> 3	Tack Socket	2 halves
<input type="checkbox"/> 4	Halyard Swivel Assembly	1
<input type="checkbox"/> 5	Feed Section	1
<input type="checkbox"/> 6	Splice Pieces	2 halves per luff sec.
<input type="checkbox"/> 7	Luff Bearings	1 per luff sec.
<input type="checkbox"/> 8	Luff Sections	determined by headstay length
<input type="checkbox"/> 9	Top Bearings With 2 Rivets	2 halves
<input type="checkbox"/> Not shown	Drive Rivets	4 per luff sec.
<input type="checkbox"/> Not shown	Tube of Silicone Seal	1

TOOLS REQUIRED FOR ASSEMBLY

- | | |
|----------------------------|---------------------------------|
| 1. Tape Measure | 5. Hack saw |
| 2. Rigging tape | 6. Fine metal file or sandpaper |
| 3. Felt tip marker | 7. Hammer |
| 4. Allen wrench (included) | |

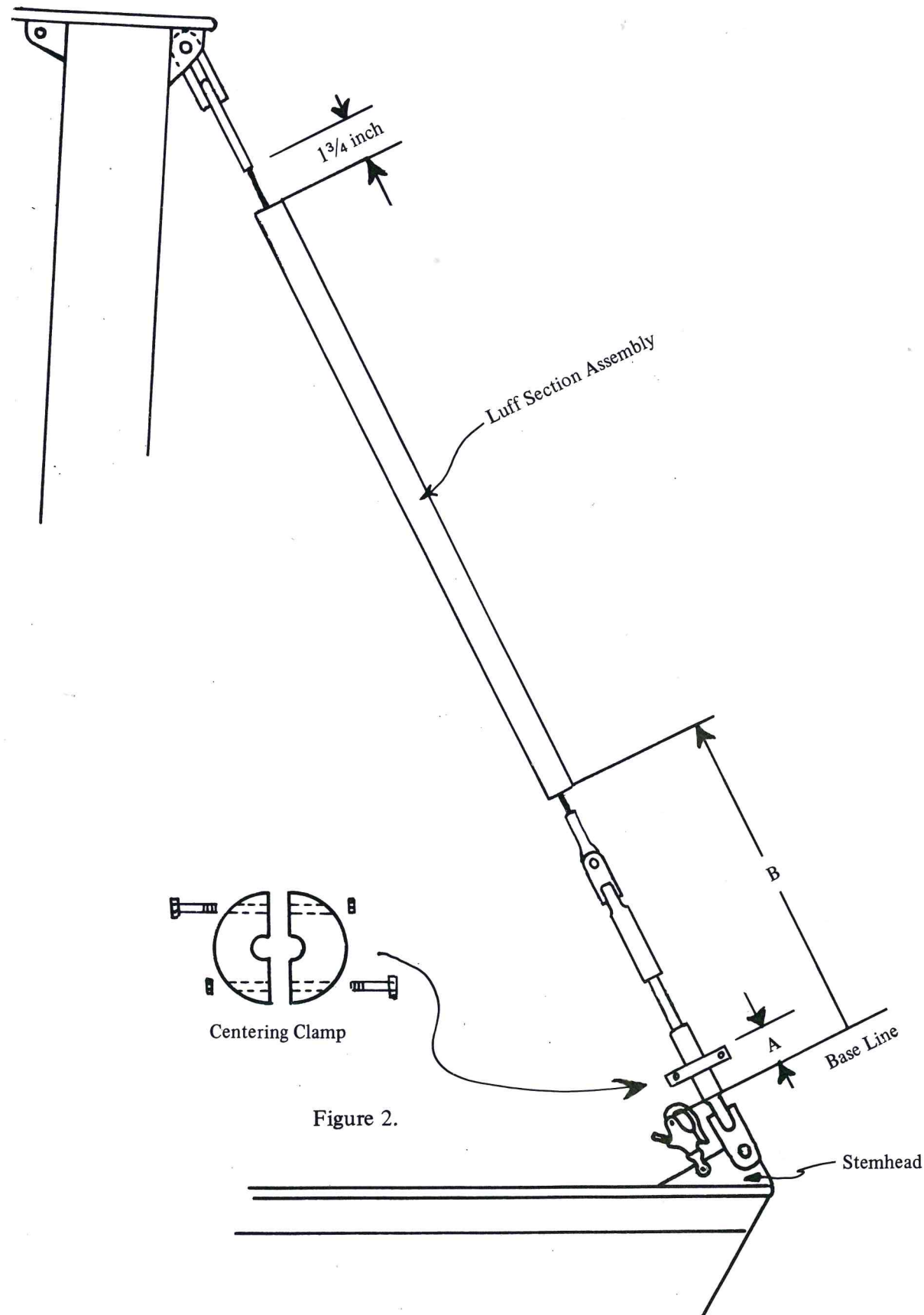

INSTALLATION MEASURING THE HEADSTAY

1. The Sea Furl Drive Unit should be attached to the deck with a shackle (not supplied). Choose an appropriate shackle (either a snap shackle or twist shackle) to use for this purpose. In most cases, the shackle that was used to tack the genoa to the stemhead fitting will work. Make sure the shackle will fit through the stainless steel grommet on the bottom of the Drive Unit.
2. Determine the **Base Line** (from which all other measurements will be taken) by aligning the shackle parallel with the headstay and noting where the shackle will bear on the grommet after the unit is installed. Mark this position with a felt tip marker on the headstay (or turnbuckle, if there is one). If the headstay is on the ground rather than on the boat, make your best estimate of where the **Base Line** position will be, based on the shackle length and stemhead configuration. The exact position of the **Base Line** is not critical as adjustments can be made after the unit is installed. However, every effort should be made to determine this position to within $\pm 1"$.
3. The **Centering Clamp** serves the purpose of centering the lower end of the Drive Unit on the headstay. It also serves to hold the furling unit up when halyard tension is released.

Determine the position of the **Centering Clamp** on the headstay by measuring up from the **Base Line** to the upper side of the clamp (measurement "A" on Figure 2) as follows:

Model #705 - A = 1 1/2"

Model #810 - A = 1 1/2"

Model #915 - A = 2 1/4"

Mark this position on the headstay.

4. The **Centering Clamp** should be drilled out and filed if necessary to fit the contour of the headstay or headstay turnbuckle. Clamp the **Centering Clamp** to the headstay (or turnbuckle) in its proper location.
5. At this point, the headstay should be removed from the boat.
6. With the headstay laid out straight on the ground, measure up from the **Base Line** to the location where the luff section assembly will start (Dimension "B", Figure 2) as follows:

Model #705 - B = 19 1/2"

Model #810 - B = 25"

Model #915 - B = 32"

Mark this position on the headstay with felt tip marker.

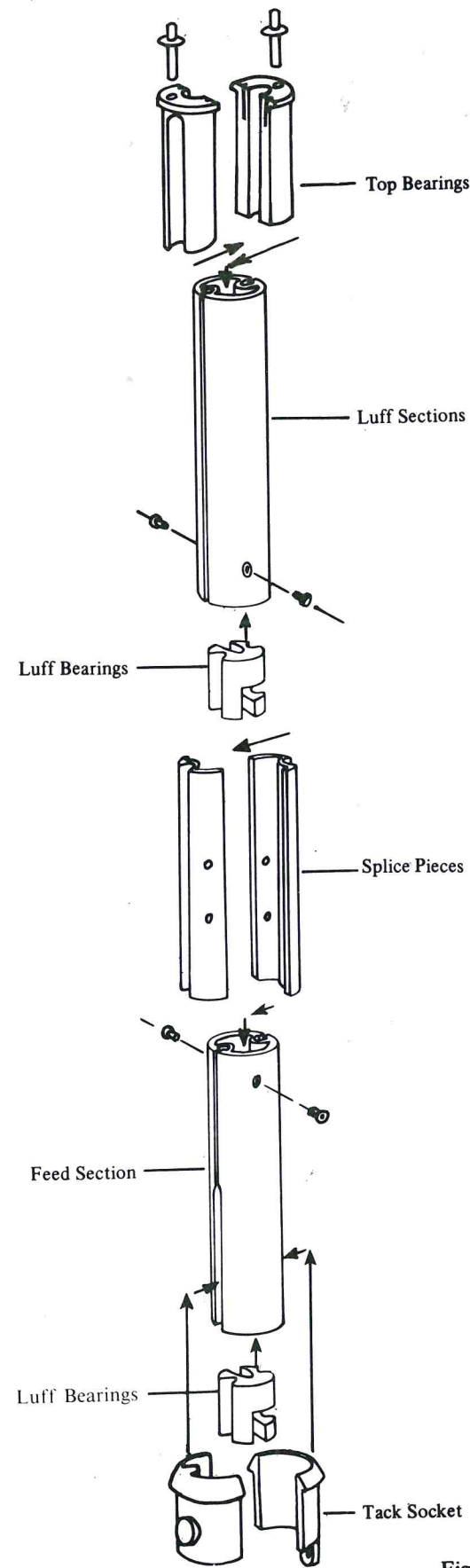

Figure 3.

EXTRUSION ASSEMBLY

1. Locate the **Feed Section** from the **Luff Sections**. The **Feed Section** can be identified as the section which has its luff grooves machined open at its lower end.

Slide the **Feed Section** over the top of the headstay; lower end first. The **Feed Section** is designed so that a standard marine wire end fitting will pass through the inside of the section. Slide this section all the way down the headstay until its lower end is even with the mark which locates the lower end of the **Luff Section** assembly (determined in step 6 on page 5).

2. Take one of the black plastic **Luff Bearings** and twist it onto the headstay above the **Feed Section**. Insert it into the top of the **Feed Section**.
3. Take two of the **Splice Pieces** and mate them together as a pair around the headstay. Insert them into the top of the **Feed Section**.
4. Line up the two holes in the pair of **Splice Pieces** with the two larger holes in the upper end of the **Feed Section**. Insert a rivet into each hole and fasten them with a hammer. Note that the head of the rivet should sit inside the larger hole in the **Feed Section** locking the **Splice Pieces** into place.
5. Take one of the **Luff Sections** and slide it over the top of the headstay. Slide it down over the **Splice Pieces** that are now sticking out of the top of the **Feed Section**. Rivet the **Luff Section** to the **Splice Pieces**. Twist another **Luff Bearing** onto the headstay and insert it into the top of the **Luff Section**. Rivet another set of splice pieces into the top of the section.
6. Repeat step 5 until the top of the **Luff Section** assembly comes within 6' of the top of the headstay.
7. The last section to be assembled should be cut so that when assembled there will be $1\frac{3}{4}$ " between the top of the **Luff Section** assembly and the bottom of the wire terminal (Figure 2).

After cutting this upper **Luff Section** (be sure to deburr the edges), slide it over the top of the headstay and rivet it to the **Splice Pieces** which are attached to the next lower section. Before riveting, check to make sure the distance between the top of the **Luff Section** and the end of the wire terminal is $1\frac{3}{4}$ ". After riveting, insert a **Luff Bearing** into the top of the **Luff Section**. To complete the **Luff Section** assembly, insert the two halves of the **Top Bearing** into the top of the section assembly. The **Top Bearing** should be installed in Top Section and secured with rivets supplied

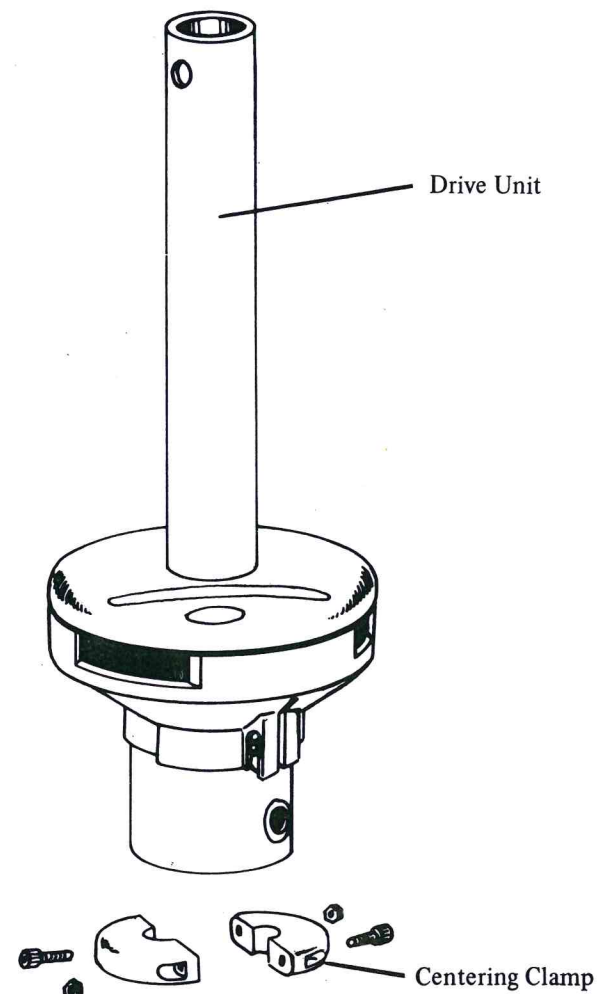
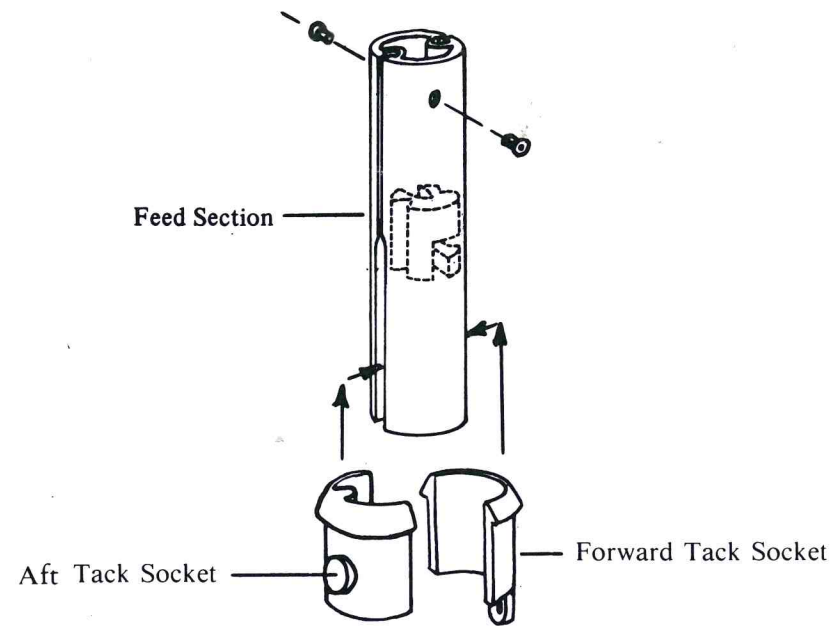

(Figure 3A)

8. Now attach the Drive Unit to the Luff Section assembly as follows:

Remove the Centering Clamp

Slide the Drive Unit up over the bottom of the headstay and Feed Section.

Reattach the Centering Clamp to the headstay in its proper location.

Slide the Drive Unit back down over the Centering Clamp.

To assemble the feed section to the drive unit, attach the aft tack socket to the feed section (Figure 3A) and insert into drive assembly, aligning the "knob" on the tack socket with the hole in the tube. Slide the Forward tack socket into the other side and tighten the screw. Use silicone seal on the threads to prevent loosening.

9. Slide the Halyard Swivel Assembly down over the top of the headstay. The tabs on the inserts should be down.

Assembly Is Now Complete.

10. Connect the completed furling unit to the boat.

Note: Make sure that Luff Bearing is installed in Feed Section at the lower end of Feed Section just above Aft Tack Socket.

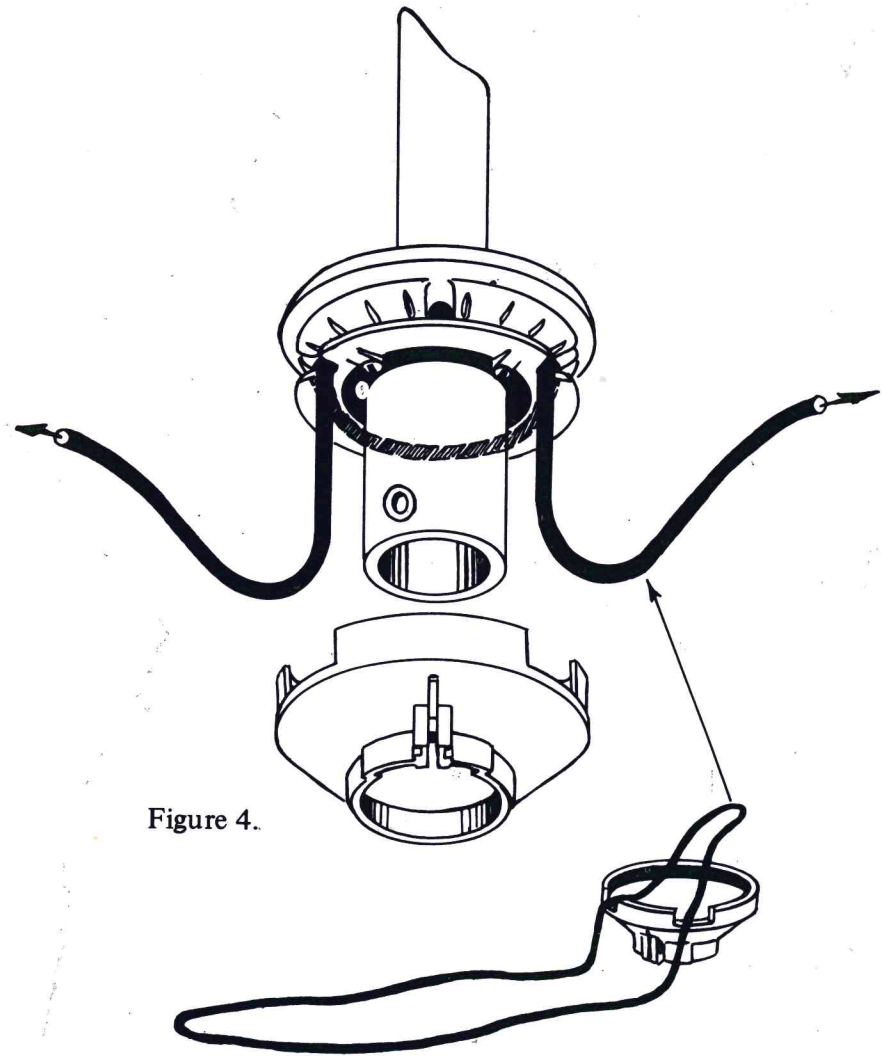

Figure 4.

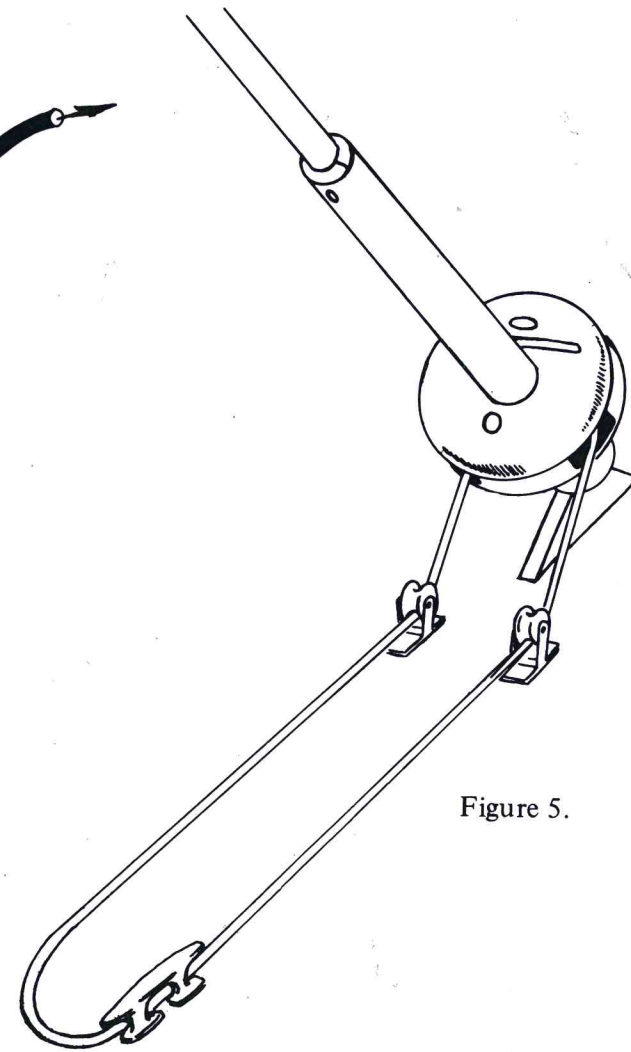

Figure 5.

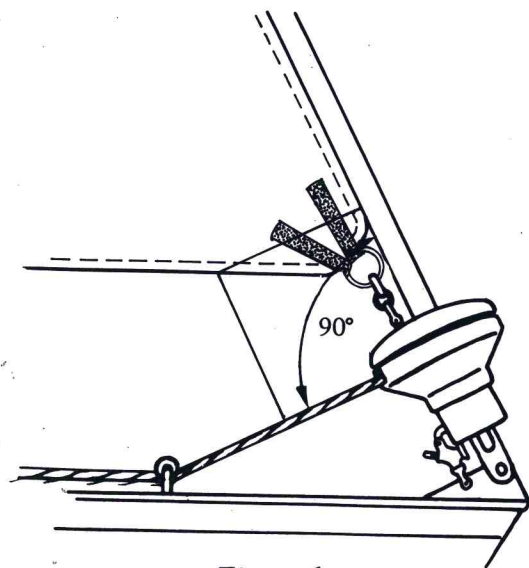

Figure 6.

FURLING LINE INSTALLATION

The Sea Furl models #810 and #915 are driven with a continuous loop of 7/16" diameter line. Model #705 is driven with a continuous loop of 3/8" diameter line. The furling line should be run through the appropriate lead blocks and around the **Drive Sheave**. The ends of the furling line should be spliced to form a continuous loop. Be sure to run the line through the fairlead blocks before splicing. The loop should be long enough to reach back to the cockpit where it can be lead to a winch or to a cleat.

The angle between the headstay and furling line leading to the 1st fairlead blocks should be 90° as shown in Figure 6. This will prevent chafe and friction on the drive unit assembly.

We suggest the use of Yale Cordage ULS™ yacht braid.

MAINTENANCE

To flush the Drive Unit Assembly loosen the Sheave Cover Screw (Figure 9, #19) and slide the Sheave Cover (Figure 9, #17) down. (Be careful not to lose the Rope Stripper (Figure 9, #11)). Spray water up into the area where the top of the Bearing Tube With Grommet (Figure 9, #16) intersects the Sheave Bottom (Figure 9, #10). Rotate the drive assembly while flushing to allow the balls to turn and the entire area to be saturated with water. Spray WD-40 into the same area. Replace the Sheave Cover.

Next, spray water up into the Bearing Tube With Grommet (Figure 9 #16) from the bottom, again rotating the Drive Assembly while spraying. Using an extension in the nozzle of the can of WD-40, spray up into the lower bearings. You may want to have a rag handy to catch the excess WD-40 which may run down.

To flush the Halyard Swivel Assembly simply spray or pour water into the bearings while turning the Swivel Cups (Figure 10, #7). An occasional squirt of WD-40 in the bearings is also recommended.

If after extensive use, or at any time stickiness or friction becomes excessive such that the bearings are not functioning acceptably, remove the entire offending assembly from the boat and return it to a Hood Yacht Systems Dealer or distributor for servicing. *At no time attempt to disassemble these Swivel (Bearing) Units.*

STORAGE AND RIGGING

When rigging or unrigging your Seafurl for storage or any other reason, every attempt should be made to keep it as straight as possible. When storing, the entire unit can be lashed to the mast or supported on a mast rack.

If your fairlead blocks are permanently fixed to the deck, it will be necessary to remove the sheave cover before storage since your furling line is spliced into a continuous loop. To remove the Sheave Cover (Figure 9, #17), loosen the Cover Clamp Screw (Figure 9, #19) and slide the cover off the bottom. Be careful not to lose the Rope Stripper (Figure 9, #11).

For the sake of protection, you may want to remove the Drive Unit Assembly (Figure 1, #1) and Halyard Swivel Assembly (Figure 1, #4) and store them at home for the winter.

OPERATION

When reefing or furling your sail, it is important to head up into the wind and ease sheets. Keep minimal sheet tension to hold a tight furl. If you have your halyard tightened up to maintain luff shape, ease the halyard to help prevent halyard wrapping and to free up the movement in the system.

Due to the great variation in masthead construction, sail stretch and individual halyard loads, the following sail installation steps should be carefully followed. If you install your Seafurl as follows, a smoothly operating system will be assured.

Attach the head of the sail to the lower shackle of the halyard swivel, but **DO NOT** attach the tack.

Feed the sail tape into one of the luff grooves as you hoist it.

Hoist the swivel and sail as high as it will go, without straining, and secure. Be careful not to hoist the halyard swivel beyond the extrusion. Downhaul the sail, utilizing a spare line temporarily attached to the sail tack and lead through the line drive sheave shackle until the maximum desired luff tension is achieved.

Furl and unfurl the sail several times while watching the halyard swivel to see if it is rotating smoothly and not being restricted in its operation.

If the final distance between the sail tack and tack shackle "X" (Figure 7) is greater than 6" the temporary lashing should be replaced with a permanent wire pennant. This pennant can be placed either between the head of the sail and the halyard swivel or between the tack of the sail and the tack shackle on the drive sheave. If this distance "X" is less than 6", a pennant lashing (a minimum of 3 turns of line) can be used.

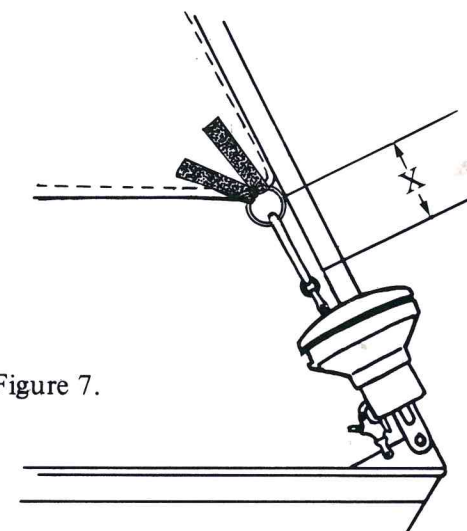
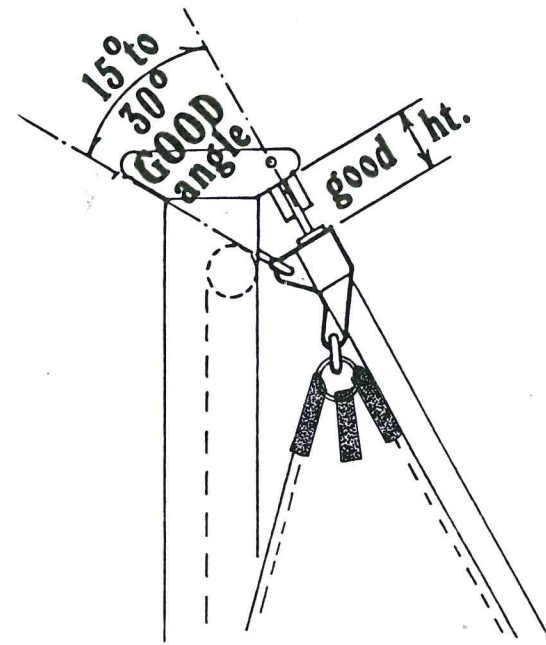
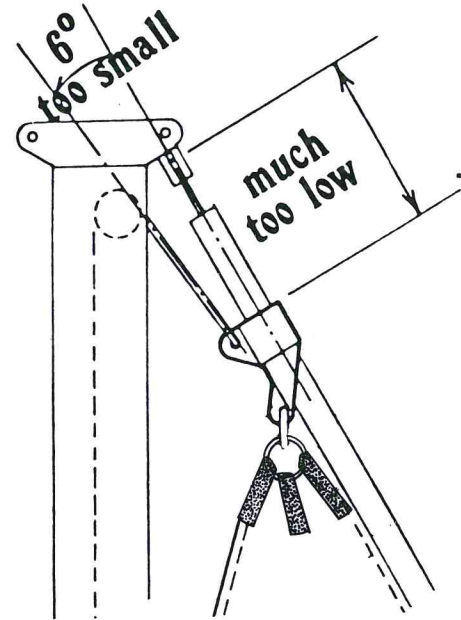

Figure 7.

An ideal circumstance is when the halyard swivel is hoisted to the end of the luff sections and has an angle (aft) between the headstay and the halyard sheave of 15 degrees to 30 degrees.



The swivel is too low, decreasing the angle between the headstay sheave and halyard sheave to 6 degrees. While this installation may function, it would be better to attach a pennant.



The pennant increased the height and angle of the swivel to the headstay. Pennants may be installed on the tack of the sail instead of at the head. This provides better leeward visibility and reduces possible damage to the sail due to heavy sea conditions.

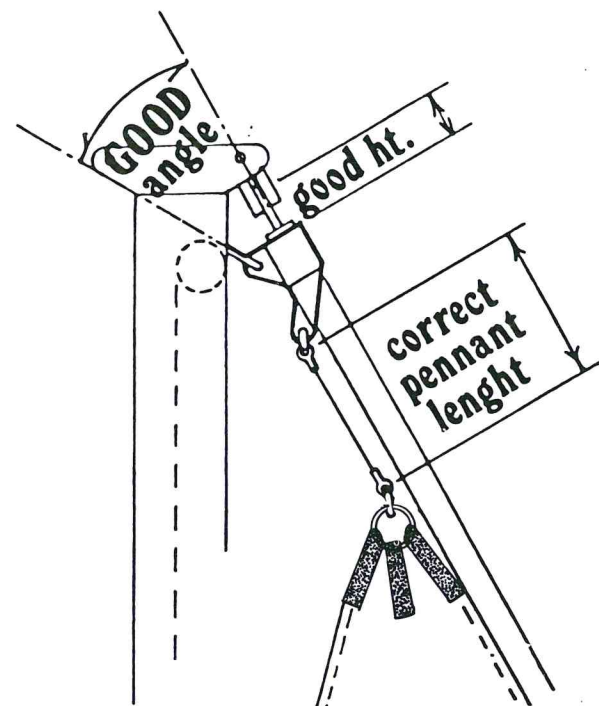

Shows a common problem caused by the location of the masthead sheave. A bad angle (no aft restraining force) is created between the headstay and sheave. This condition is aggravated by the swivel not being high enough on the luff section.

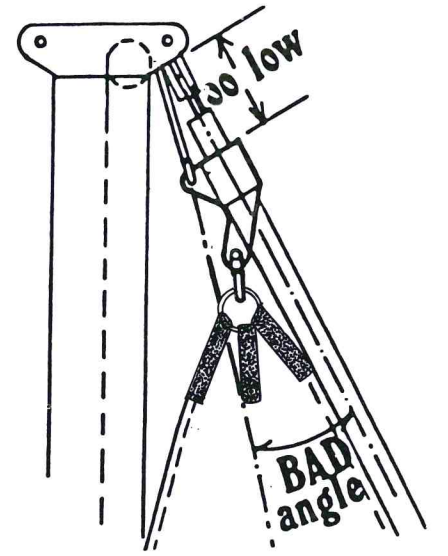

Here the swivel height is improved so there is a better angle and the exposed halyard is much shorter.

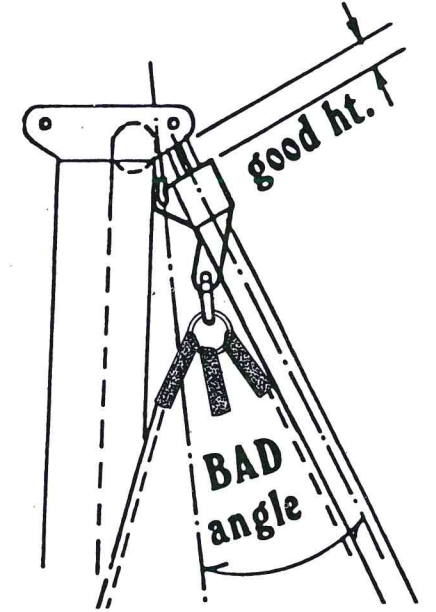

Another alternative is to install a strap bale or block that restrains the halyard. Without such a device, the condition illustrated in Fig. 12 would cause halyard wrap problems.

Note: The angle shown here is exaggerated for illustration purposes. The bale should be placed so that halyard just lightly rubs on the inside of the bale. We recommend the Forespar P.E. - 35C pad eye when a bale is necessary.

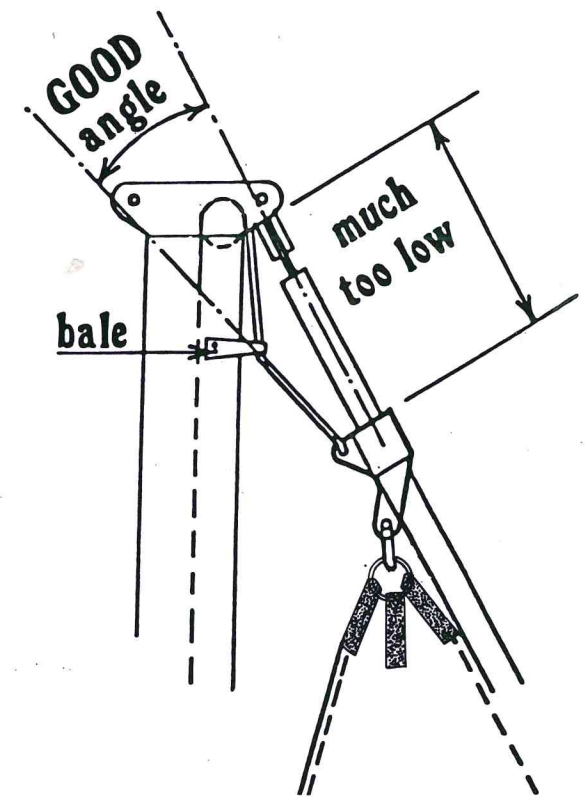

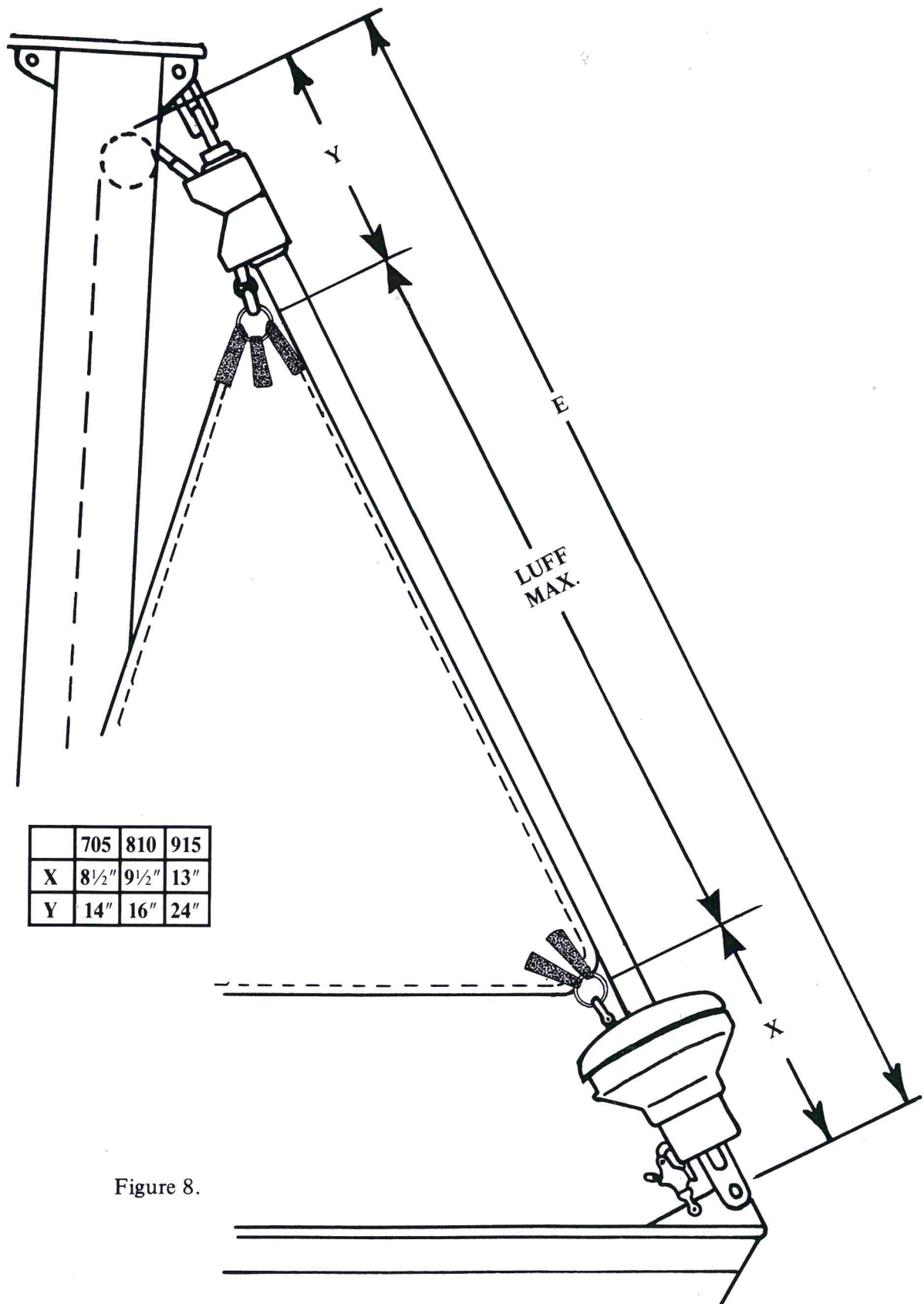

Figure 8.

SEA FURL SAILS

Precisely measure the distance from the top of the halyard sheave (at the mast-head) to the center of the stemhead pin (Dimension E, Figure 8).

To determine the maximum luff dimensions for your sail use the table below:

Overall length from sheave top to Stemhead Pin "E"	_____
Halyard swivel deduction Y - (See Table Figure 8)	_____
Drum assembly deduction X - (See Table Figure 8)	_____
Maximum sail luff length	=====

Hood Size "X" or 3/16" diameter bolt rope tape must be used on the luff so that the sail easily slides up and down, yet doesn't pull out in heavy air.

In order to accommodate the halyard swivel and tack shackles, the head and tack rings in sail should be sewn in with webbed in stainless steel rings. The rings should be no smaller than 1½" x ¼" for 810 and 915 and 1¼" x 3/16" for the 705.

DRIVE UNIT ASSEMBLY

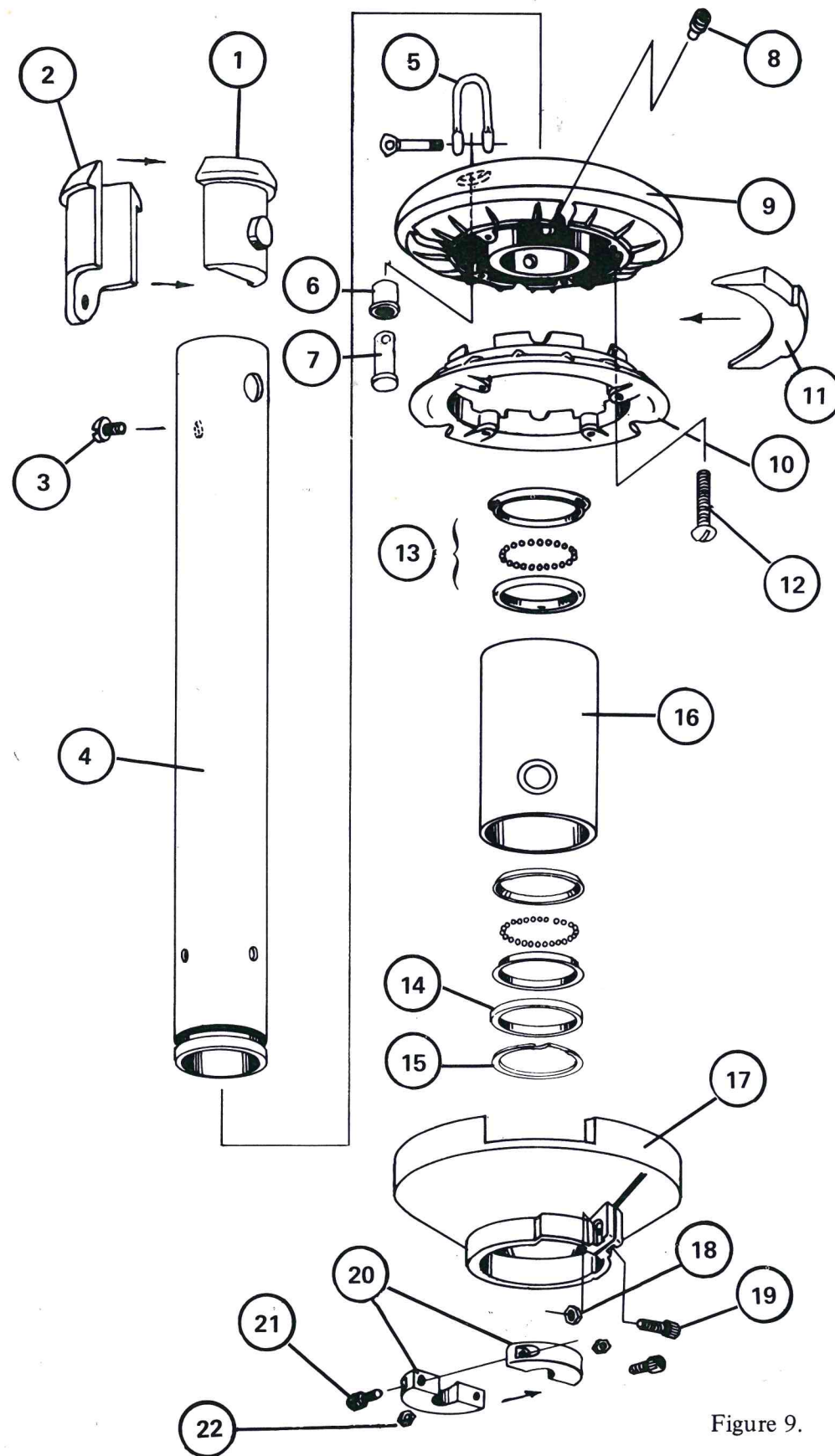

Figure 9.

NOTE:

This exploded view is meant for purposes of product parts identification only. Please do not attempt to disassemble. Please refer to Maintenance section of this manual for maintenance procedure.

Reference #	Description	Part Number		
		705	810	915
1.	Aft Tack Socket	6405-001	5960-001	5997-001
2.	Forward Tack Socket	6406-001	5959-001	5998-001
3.	Tack Socket Screw	1/4-28 x 1/4 SHCS	1/4-20x3/8 SHCS	1/4-20x3/8 SHCS
4.	Turnbuckle Tube	6402-001	5958-001	6001-001
5.	D Shackle	Wichard 1212	Wichard 1213	Wichard 1214
6.	Shackle Stud Bushing	6412-001	5983-001	5994-001
7.	Shackle Stud	6411-001	5982-001	5993-001
8.	Sheave Set Screw	3/8-24 x 3/8 half Dog pt Set Screw	3/8-16x1/4 half Dog pt Set Screw	3/8-16x5/16 full Dog pt Set Screw
9.	Sheave Top	6395-001	6021-001	6102-001
10.	Sheave Bottom	6397-001	5979-001	6005-001
11.	Rope Stripper	6427-001	5984-001	5996-001
12.	Sheave Assembly Screw	1/4-20 x 3/4 RHMS	1/4-20x1 RHMS	5/16-18x1 RHMS
13.	Bearing Assembly	6478-000	6181-000	6182-001
14.	Bearing Thrust Washer	6410-001	5957-001	5995-001
15.	Spirolox Ring	RSN 168 S	RSN 200 S	RSN 237 S
16.	Bearing Tube /w Grommet	6401-001	5980-001	5991-001
17.	Sheave Cover	6396-001	5977-001	6006-001
18.	Cover Clamp Nut	1/4-20 Hex Jam Nut	1/4-20 Hex Jam Nut	5/16-18 Hex Jam Nut
19.	Cover Clamp Screw	1/4-20 x 3/4 SHCS	1/4-20x3/4 SHCS	5/16-18x1 SHCS
20.	Centering Clamp	6429-001	5961-001	5999-001
21.	Centering Clamp Screw	1/4-20 x 1 RHMS	1/4-20x1 RHMS	1/4-20x1 RHMS
22.	Centering Clamp Nut	1/4-20 Hex Jam Nut	1/4-20 Hex Jam Nut	1/4-20 Hex Jam Nut

705 LD
Drive Unit Assembly Complete

6435-000

810 LD
Drive Unit Assembly Complete

6013-000

915 LD
Drive Unit Assembly Complete

6000-000

HALYARD SWIVEL ASSEMBLY

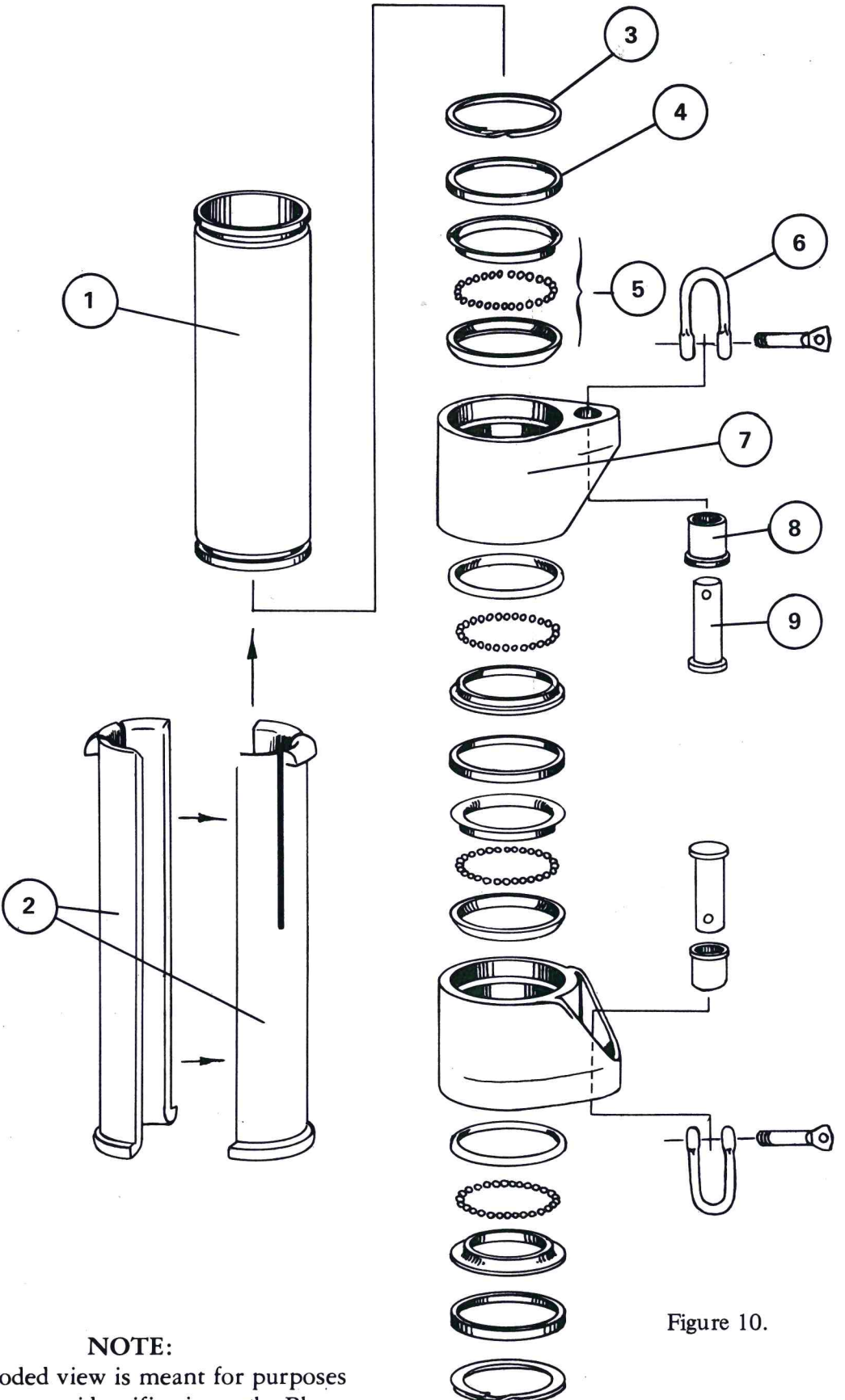

Figure 10.

NOTE:
 This exploded view is meant for purposes of product parts identification only. Please do not attempt to disassemble. Please refer to Maintenance section of this manual for maintenance procedure.

Reference #	Description	Part Number		
		705 LD	810 LD	915 LD
1.	Swivel Tube	6407-001	6012-001	6016-001
2.	Halyard Swivel Inserts	N/A	6017-001	6018-000
3.	Spirolox Ring	RSN 168S	RSN 200S	RSN 237S
4.	Bearing Thrust Washer	6410-001	5957-001	5995-001
5.	Bearing Assembly	6478-000	6181-001	6182-001
6.	D Shackle	Wichard 1212	Wichard 1213	Wichard 1214
7.	Halyard Swivel Cup	6398-001	6011-001	6015-001
8.	Shackle Stud Bushing	6412-001	5983-001	5994-001
9.	Shackle Stud	6411-001	5982-001	5993-001
705 LD Halyard Swivel Assembly Complete		6430-000		
810 LD Halyard Swivel Assembly Complete			6010-000	
915 LD Halyard Swivel Assembly Complete				6014-000

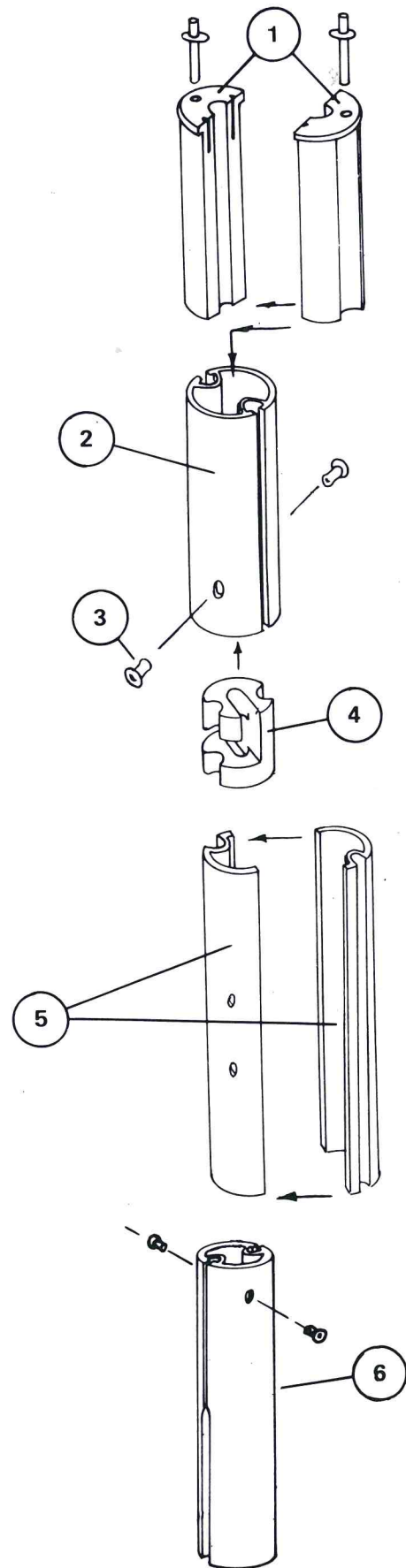

Figure 11.

LUFF SECTION ASSEMBLY

Reference #	Description	Part Number		
		705	810	915
1.	Top Bearing	6428-001	6019-001	6020-001
2.	Luff Section	6432-001	5945-001	5946-001
3.	Rivet	3/16 Aluminum Drive Rivet		
4.	Luff Bearing	6431-001	5985-001	6007-001
5.	Splice Piece	6404-001	6112-001	6113-001
6.	Feed Section	6433-001	6125-001	6126-001

Hood Limited Warranty for Sea Furl/Gemini Products

- I. **WARRANTY:** Hood Yacht Systems warrants that Hood Sea Furl and Gemini headstay products will be free from defects in material and workmanship for a period of one year. That period shall commence upon receipt of the Hood warranty registration card within 30 days upon receipt of the goods. Any part which proves defective in normal usage during the one year period will be repaired or replaced by Hood Yacht Systems.

This warranty is subject to the following conditions and limitations:

- A. Hood Yacht Systems liability shall be limited to repair or replacement, at Hood Yacht Systems discretion, of goods or parts defective in materials or workmanship. This shall be the buyer's exclusive remedy.
- B. Except where otherwise specified, quality shall be in accordance with Hood Yacht Systems specifications.
- C. The Hood Sea Furl and Gemini must be installed and maintained properly and used under normal conditions in the application for which they were intended.
- D. Hood Yacht Systems shall not be responsible for shipping charges or installation labor associated with any warranty claims.
- E. Terms of this limited warranty shall be 90 days if the product is used in commercial, rental or charter operations as well as with respect to any swaged attachments to wire, either standing or running rigging.
- II. Failure to obtain an owner's manual or otherwise be aware of the information contained in the owner's manual may void this warranty.
- III. The limited warranty is in lieu of all other warranties; any implied warranties are limited in duration to the duration of the warranty stated here.
- IV. Hood is not responsible for consequential damages of any sort, to the extent that such exclusion is permitted by applicable law.

Hood **YACHT**
SYSTEMS

705 / 810 / 915

Owner Warranty Activation Card

To be completed and returned to Hood Yacht Systems by owner:

Date _____
Owner's Name _____
Address _____
City _____ Phone Home _____
State _____ Zip _____ Business _____
Boat Type _____
Model Purchased: _____
 705 Other _____
 810 _____
 915 _____
Bought From _____
Installed by _____ Date _____

Did you receive an owner's manual? _____

I have read the owner's manual and understand my system's operation and maintenance requirements.

Signature

There are some things I do not understand and would like a Hood Representative to contact me.

HOOD YACHT SYSTEMS, CORP.
1 Maritime Drive
Portsmouth, Rhode Island 02871
(401) 683-2900