

RS *Vision*

OWNER'S MANUAL

LDC Racing Sailboats, Trafalgar Close, Chandlers Ford. Eastleigh SO53 4BW, England
Tel. +44 (0)23 8027 4500 Fax. +44 (0)23 8027 4800

Ldc **racingsailboats.co.uk** 

CONTENTS

- 1. INTRODUCTION**
- 2. SPECIFICATIONS AND DRAWINGS**
- 3. SAFETY INFORMATION**
 - 3.1 Design Category
 - 3.2 Loading
 - 3.3 Safety Equipment
 - 3.4 Capsize Recovery
 - 3.5 Air Tank
 - 3.6 Man Overboard Prevention and Recovery
 - 3.7 Use of an Outboard Engine
 - 3.8 Towing, Anchoring, Mooring and Trailing
- 4. COMMISSIONING**
 - 4.1 Preparation
 - 4.2 Unpacking
 - 4.3 Rigging the Mast
 - 4.4 Stepping the Mast
 - 4.5 Rigging the Spinnaker Halyard
 - 4.6 Rigging the Boom
 - 4.7 Hoisting the Jib
 - 4.8 The Rudder
 - 4.9 Hoisting the Mainsail
 - 4.10 Rigging the Spinnaker
 - 4.11 Completion
- 5. SAILING HINTS**
 - 5.1 Introduction
 - 5.2 Launching
 - 5.3 Leaving the beach
 - 5.4 Sailing Close-Hauled and Tacking
 - 5.5 Downwind and Gybing
 - 5.6 Using the Spinnaker
 - 5.7 Reefing



- 6. MAINTENANCE**
 - 7.1 Boat Care
 - 7.2 Foil Care
 - 7.3 Spar Care
 - 7.4 Sail Care
- 7. WARRANTY**



1. INTRODUCTION

Congratulations on the purchase of your new **RS Vision** and thank you for choosing an RS product. We are confident that you will have many hours of great sailing and racing in this truly excellent design.

The RS Vision is an exciting boat to sail and offers fantastic performance. This manual has been compiled to help you operate your RS Vision with safety and pleasure. It contains details of the craft; the equipment supplied or fitted, its systems and information on its safe operation and maintenance. Please read it carefully and be sure that you understand its contents before using your RS Vision.

This manual is not a course on boating safety or seamanship. If this is your first boat, or you are changing to a type of craft you are not familiar with, for your own safety and comfort, please ensure that you have adequate experience before assuming command of the craft. If you are unsure, your dealer or national sailing federation (the Royal Yachting Association) will be able to advise you of a local sailing school, or competent instructor.

Please keep this manual in a secure place and hand it over to the new owner if you sell the boat.

For further information, spares and accessories, please contact your local dealer or:

LDC Racing Sailboats

Trafalgar Close

Chandlers Ford

Eastleigh

Hants SO53 4BW

Tel. 023 8027 4500

Fax. 023 8027 4800

Email. rs@ldcracingsailboats.co.uk



2. SPECIFICATIONS AND DRAWINGS

Identification.

Your RS Vision can be identified by two numbers, one is the sail number and the other is the Hull Identification Number.

The sail number is the number by which you register your RS Vision with insurance companies, the class association and also when you sign on for events. Not only is the sail number on the mainsail itself; it is also printed on the port side of the transom.

The Hull Identification Number, or HIN, is required by European law. Every new boat sold should display a HIN to show that it meets all the guidelines set by the European community and is safe to use up to the conditions mentioned in 3.1 Design Category. Your RS Vision complies with European law to category C (explained later) and hence displays a HIN which is imprinted on the starboard side of the transom.

The HIN is purely to show that your RS Vision meets European regulation, and therefore should be referred to by its sail number.

Dimensions.

Length Overall (LOA):	4.55 m	15'0"
Beam:	1.75 m	5' 9"
Hull Weight:	130 kg	lb
Reefing Mainsail:	m ²	sq ft
3 Batten Mainsail:	m ²	sq ft
Jib:	m ²	sq ft
Spinnaker:	m ²	sq ft

3. SAFETY INFORMATION

Personal preparation and owner's responsibility.

Before attempting to operate the boat, ensure that you have appropriate experience to handle the boat safely in the anticipated sea and wind conditions, and that all the crew have sufficient boating experience and that they are familiar with emergency procedures (man overboard recovery, towing).

Always check the weather forecast before leaving shore, and ensure that the predicted weather and sea conditions are suitable for the boat (see 3.1). clothing should be suitable for the anticipated weather conditions and footwear appropriate for boating.

Before going afloat, all persons should be wearing a suitable buoyancy aid (life jacket or personal floatation device), which should be worn at all time when on the water. Note that in some countries it is a legal requirement to wear a buoyancy aid that complies with their national regulations at all times.

It is recommended that you carry a whistle or horn to attract attention in case outside assistance is required.

The owner/operator is responsible for the safe operation of the boat. His/her responsibilities include properly preparing and maintaining the boat and safety equipment, knowledge of the boat operation, safety training of the crew, following the navigation rules (including knowledge of the Collision Regulations and local navigation rules), care of the environment, insurance and where necessary registration.



3.1 Design Category.

The RS Vision is a Design Category C boat. The definition of this category is:

- Design Category: C – ‘inshore’
- Description of Use: Designed for voyages in costal waters, large bays, estuaries, lakes and rivers.
- Wind Force: Up to, and including Beaufort force 6.
- Significant Wave Height: up to, and including 2 m.

The RS Vision complies with this design category, subject to:

- The crew having suitable skill and experience.
- Satisfactory construction and maintenance of the boat and its equipment.

Users of this boat are advised that:

- All crew should receive suitable training.
- The boat should not carry more than the maximum load.
- Any water in the hull should be kept to a minimum.
- Stability is reduced by any weight added high up.

3.2 Loading.

The RS Vision is designed to be sailed by no more than 4 people. However it is recommended that you do not exceed the maximum loading of 320 kg, including any equipment added to the basic rigged boat, e.g. an anchor. To enable the boat to be righted safely the minimum recommended crew weight is 60 kg.

All the crew and equipment should be evenly distributed to ensure that the boat is upright and approximately level. Heavy items, such as an anchor, should be securely fixed to avoid movement when underway.

3.3 Safety Equipment.

It is your responsibility to ensure that all necessary safety equipment is obtained for the type of sailing you are participating in and it is readily accessible on board while the boat is in operation.

HINT

We recommend that you sail in a location where there is adequate rescue cover, should you get into any difficulty, especially whilst learning to sail your new boat.

3.4 Capsize Recovery.

No matter how stable and secure your RS Vision feels on the water, a capsize will be inevitable. Properly handled a capsize can be fun and definitely not something to worry about. Like everything it is best to practice on a quieter day, and preferably with a safety boat to hand.

Recovery technique.

As the boat capsizes, you should endeavour to fall cleanly into the water, trying to avoid catching sheets or toestraps as you fall. You should initially ensure that:

1. If you are using the spinnaker that it is fully recovered in the chute.
2. The main and jib sheets are both uncleated.

WARNING

If the boat has capsized “on top” of you, or “to windward” as it is known, there is more chance of the boat inverting and you should ensure that you and your crew are well clear as the boat fully inverts.

If you are sailing with a crew, he or she should float in between the cockpit and the boom, awaiting instructions from the helm. Then you should proceed round to the transom where the righting line is stowed. Unclip the “high side” righting line, and keep hold of it as you proceed around the rudder to the centreboard area. If the boat has inverted the righting line is easier to locate.

If the boat has inverted:

The righting line will help you climb onto the hull if it is inverted, it being best to use the line across the hull. Stand on the underneath of the gunwhale (now facing upwards), adjacent to the centreboard, where there is a grippy surface for feet or knees. Pull on the righting line from across the upturned hull and as the boat starts to come back up try to work your way up the hull and onto the centreboard, as it comes horizontal. Do not worry if you are unable to do so.

If the boat is on its side:

Hold the righting line as high up as you can, and brace your feet against the hull, and pull. The boat will start to come upright, and as it does work your hands up the righting line towards the gunwhale.

WARNING

If the mast is lying into the wind as you pull it up the boat will flip up quickly and you should be aware to work your way up the righting line to the gunwhale a bit quicker.

Once the boat is upright and you are in the water holding the righting line, you can either use the righting line as a step to push yourself up, grab the toestay and haul yourself in or go around to the transom and climb in over there. To make this easier, if sailing with a crew they should be scooped up into the cockpit as the boat is righted (the “scoop method”). Once in the boat the crew can assist the helm to get back on board.

If you did manage to get onto the centreboard as the boat came up from full inversion, or if you were nimble enough to hop over onto the board as the boat capsized, then it is a simple case of pulling on the line (or just the gunwhale if you are heavy enough), and hopping in as the boat comes upright. “Sprawling in” is often a more accurate term, but the net effect is that you end up in the boat without falling back into the water! Effecting the “dry” capsize, where you manage to hop on the board as you go over and then back into the boat as it comes upright is the ultimate goal that will come with practice!

Getting going again:

Once you are back aboard you will find the water quickly drains out the transom or down the centreboard case. It is worth taking time to sort yourself out, clipping the righting line(s) back on at the transom, and securing them in the notch just below the gunwhale at the transom corner. Congratulations on a successful recovery!

3.5 Air Tank.

The RS Vision is equipped with a sealed buoyancy compartment just in case of capsize or swamping. The buoyancy compartment is formed by the hull and deck mouldings and consequently the following points should be noted:

- ! **Do not puncture the buoyancy compartment.**
- ! **Should the buoyancy compartment become punctured, do not use the boat until the compartment is properly repaired. If in any doubt, contact RS Racing for repair details.**

- ! It is against class rules to add any fittings; you may have to replace fittings from time to time. Ensure that all fastenings are resealed properly using an appropriate sealant. If in any doubt, contact RS Racing for details.

3.6 Man Overboard Prevention and Recovery.

Working deck.

The working deck of the RS Vision, which is intended to be occupied when the boat is afloat, is the areas covered with a none slip coating (as seen in picture 3.1). These areas are:

- The entire cockpit floor, including kick-blocks and daggerboard case, from the aft end up to the mast foot.
- The top surface and outside edge of the side deck from the aft end to the recess for the shroud points.
- The central thwart can also be used as a place to sit. It is not recommended that this is used as somewhere to stand as it does not have a non-slip texture and may be slippery.

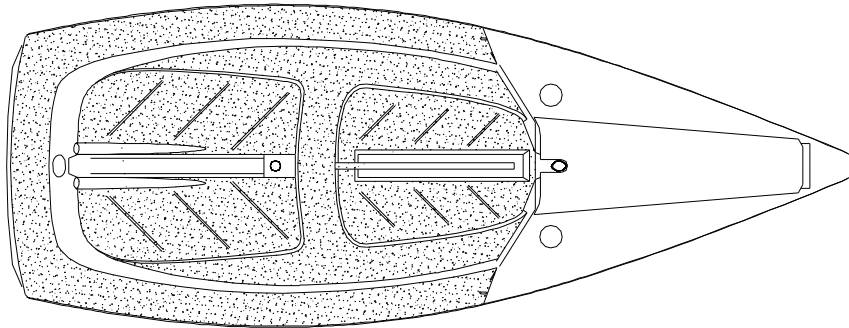

Picture 3.1 Working deck area



Crew overboard recovery.

The RS Vision is designed to be sailed by up to four people. However, it can be sailed single-handed. If sailing alone it is recommended that you ensure adequate safety cover is in attendance before launching.

Should you fall overboard, whilst sailing alone, the boat will soon capsize allowing you to swim to it and follow the righting from capsize procedures previously mentioned in this manual.

To recover a crew member from the water:

- The helm should bring the boat just downwind of the person in the water.
- The helm should balance the boat, using a combination of body weight movement and sail pressure.
- The crew should board the boat via the windward gunwale with the help of another member of the crew. Or it may be easier to board over the transom using the rear toestrap to help pull yourself in.

HINT

By completing a recognised sailing instruction course, you will learn how to recover a man over board quickly and effectively. We recommend attending a sailing course if you have not already done so.

3.7 Use of an Outboard Engine.

The RS Vision has been designed for use with an outboard, providing:

- The specific RS Vision outboard bracket kit has been fitted as per the instructions supplied in the kit.
- The outboard motor does not exceed 2.5 hp.



It is the responsibility of the helm to ensure the safe use of any outboard motor fitted. If in doubt adequate training should be sought from the dealer or recognised sailing institution.

3.8 Towing, Anchoring, Mooring and Trailing.

Towing.

Should it become necessary to tow your RS Vision, you should follow the procedure below:

- Secure the towing line around the tack bar. Or alternatively pass the towing line through the jib tack shackle and then tie securely around the mast as close to deck level as possible.
- Lower or furl all the sails.
- Fully raise the centreboard.
- Stay at the tiller. In the event of rudder loss, sit well aft.

Anchoring.

The RS Vision can be anchored for short periods of time. If anchoring is going to be attempted, then we recommend attending a sailing course to learn how to anchor safely.

If you do wish to anchor your RS Vision, the anchor line should be secured round the tack bar, or alternatively pass the towing line through the jib tack shackle and then tie securely around the mast as close to deck level as possible. The sails should be lowered or securely stowed and the rudder and centreboard should be raised completely.

REMEMBER

An anchor is a heavy piece of equipment so you must ensure that you are not overloading your Vision and that it is securely stowed to prevent it damaging the boat or you!



Mooring.



The RS Vision can be moored on a buoy or a pontoon for short periods. When mooring on a buoy, ensure the mooring line is securely fastened to the tack bar.

When mooring along side a pontoon, a mooring line can be attached to tack bar and around the aft end of the rear toestraps. Always remember to use some padding between your Vision and the object you are mooring against!

Trailing.

The RS Vision can be trailed behind the majority of cars. When trailing your RS Vision you should only use an approved trolley and road base. Tying down the boat to its trailer is important because too much or too little tension could result in damage. Follow the instructions below for safe trailing:

- Ensure the boat is located correctly on the trolley, with the gunwale supports up under the gunwales and the bow located in the bow snubber of the trolley.
- Ensure the trolley is properly located on the road base and the retaining pin is fitted.
- Tie the boat down to the trailer at the bow and across the middle. You only need to apply sufficient tension to hold the boat in contact with the trolley supports. Use padding material where any straps touch the deck.

HINT

It is always a good idea to tie the boat down when it is left in the dinghy compound to prevent any damage to you boat, or any other, in the event of strong winds.



4. COMMISSIONING

4.1 Preparation.

Your RS Vision comes complete with all the components necessary to take the boat sailing. In order to commission it, you will need the following tools:

- Pliers or a shackle key.
- Small, flat bladed screw driver.
- PVC (electricians) tape.

You may require other tools later, should you wish to make any settings or tuning adjustments to the boat and rig.

DO NOT use a knife or other sharp object to cut through packaging containing parts – you may damage the contents!

Whilst your RS Vision has been carefully prepared, it is important that new owners should check shackles and knots are tight. This is especially important when the boat is new, as travelling can loosen seemingly tight fittings and knots. It is also important to regularly check such items prior to sailing.

4.2 Unpacking.

Having unpacked your RS Vision you should check that you have all the items listed below and in picture 4.1 and picture 4.2 before throwing away any of the packing as there may be some small items still wrapped.

- 1 x RS Vision hull.
- 1 x mast.
- 1 x boom.
- 1 x gnav bar.
- 1 x rudder.

- 1 x rudder stock, with tiller extension.
- 1 x main sail.
- 1 x jib.
- 1 x spinnaker.
- 1 x rope pack – consisting of:
 - 1 x mainsheet.
 - 1 x jib sheet.
 - 1 x spinnaker sheet.
 - 1 x rudder downhaul and block.



Picture 4.1 – Vision equipment.



Picture 4.2 – Vision rope pack

4.3 Rigging the mast.

To complete this section you will require:

- The mast
- A flat bladed screw driver.

Fitting the spreaders.

It is worth taking time over this part to ensure it is correctly completed.

Improperly fitted spreaders will result in strange sailing characteristics and may even result in failure of the mast.

1. Carefully unpack the spreaders from the top of the mast, being sure not to damage any of the securing split rings.
2. Unwind the shrouds and forestay from around the mast and unwrap from the packaging.
3. To fit the spreaders, refer to table 4.1 below and to the following page as to how to and where to fit the pins.
4. Finally, tape up all the securing pins and rings to prevent them from being damaged or damaging the spinnaker.



Class	Bracket Connection Pin		Outer End		
	Primary	Adjuster	End cap pos'n	Wire Dia.	Visible Holes
RS Vision	Aft	1A	FWD	3.0mm	1

Table 4.1 Spreader pin positions.

Now the mast is ready to be put up in the boat, or *stepped*.

REMEMBER

Check that both ends of the main halyard, jib halyard and spinnaker halyard are tied off at the bottom end of the mast so they are within easy reach when the mast is stepped.



Vernier Adjust Spreader Instructions

595-478-E

Date: 16-03-25

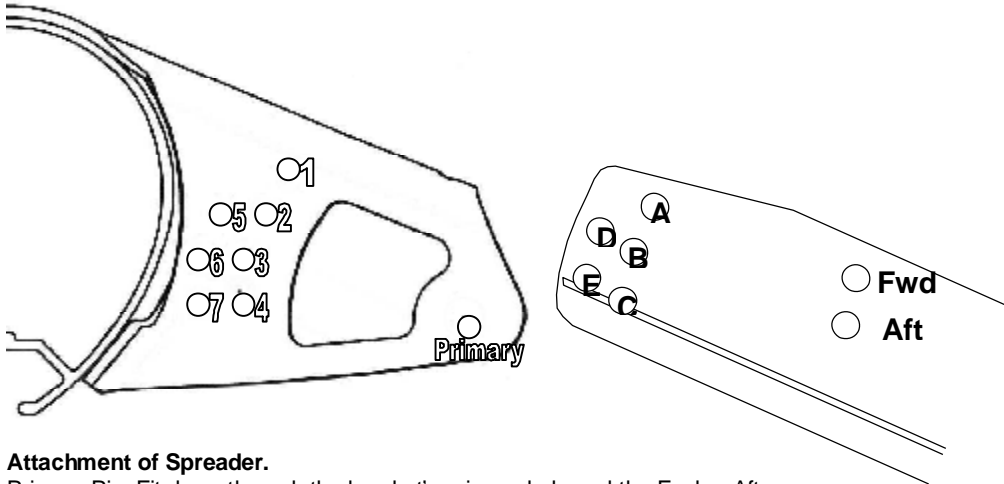

Attachment of Spreader.

Primary Pin: Fit down through the bracket's primary hole and the Fwd or Aft spreader hole as required.

Adjuster Pin: Fit down through a hole 1 to 4, and through A to C or through a hole 5 to 7, and through D to E.

Please see the table on the previous page for the specific positions.

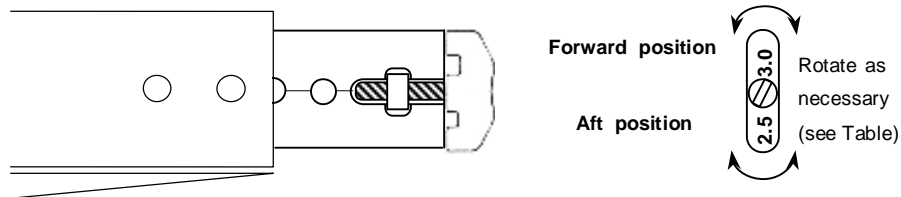

Spreader Ends

Spreader End Cap:

The spreader end cap incorporates two shroud wire slots to give a tight grip on either 2.5 or 3mm wire. The sizes are identified on the front face of the end cap (See diagram above). To find which wire slot you require for your mast, please see the table below.

The end cap can also be rotated so that the shroud can be positioned at either the forward or aft position of the spreader end (see diagram above). To find out which position is required for your mast, please see the table below.

To attach the shroud, slacken the end screw, rotate the end clamp if necessary, then insert the shroud.

Ensure that the shroud is tensioned between T-Terminal and spreader tip, then tighten the screw firmly.

This method "locks in" the dihedral angle.

Length Adjustment:

The position is described by the number of adjustment holes visible (e.g. In the diagram above there are 1 ½ holes visible). **Please see the table below for your class specific positions.**

Security

All clevis pins must be fitted with the flat head on top, and locked with a split ring. Tape all split rings, pins and the outboard end of the spreader extrusion. This will reduce chafe on the mainsail and prevent flogging sails/halyards becoming damaged.

Self-amalgamating tape is best, but pvc electrical tape is an adequate alternative.

4.4 Stepping the mast.

Before stepping the mast, makes yourself familiar with how the “foot” (bottom end) of the mast will fit into the “step” (fitted to the boat).

The mast foot has two rectangular blocks on the bottom, separated by a groove. Both these blocks will fit between the block at the front of the mast step and the bolt at the back (see picture 4.3 and 4.4).



Picture 4.3 The mast step and foot.

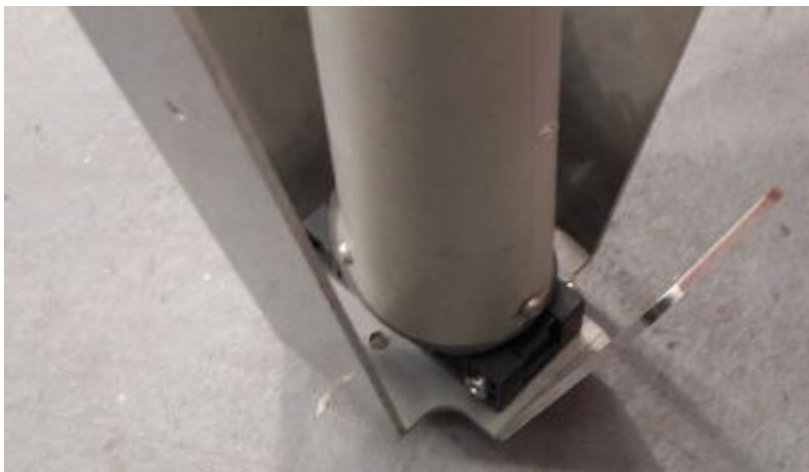

Picture 4.4 The mast foot correctly located.

It is easier to step the mast with two people, however it can be done single-handed. We will show you both methods.

Stepping the mast single-handed.

1. Ensure the mast step area is free from any blocks or rope.
2. Ensure the tack line for the spinnaker pole stays on the starboard side of the mast.
3. Stand the mast upright, putting the base of it against something to stop the mast sliding as you lift it.
4. Carry the upright mast to the side of the boat.
5. Pick up the mast, lift it over the gunwale of the boat and lower it onto the mast step (see picture 4.5).
6. Rock the mast forward into the mast gate. Now the mast is in the mast gate it is supported side to side and forwards, all you have to do is stop it falling back.
7. Untangle the forestay and pull it forwards to the tack bar and tie it off to the small eye on the port side (see picture 4.6).



Picture 4.5 Stepping the mast single-handed.



Picture 4.6 Tying the forestay.

REMEMBER

If the wind is blowing there will be a lot of pressure on the top of the mast making it wave around. Consider finding somebody to help if you feel you will struggle!

Stepping the mast with two.

This is a much easier way of stepping the mast, especially if it is windy at all.

1. Ensure the mast step area is free from any blocks or rope.
2. Ensure the tack line for the spinnaker pole stays on the starboard side of the mast.
3. Lay the mast along the boat with the mast foot over the mast step.
4. The stronger of the two people should climb into the front cockpit, but be careful not to go any further back than the trolley wheels or the boat will tip up.
5. The second person should walk round to the back of the boat and lift that end as high as possible.
6. As the top of the mast is lifted, the first person needs to guide the mast foot down into the mast step area (see picture 4.7).

7. Now the first person takes over and lifts the mast upright, making sure to push the mast down into the step as you lift (see picture 4.8).
8. Now the second person should go to the front of the boat and tie the forestay on as above.



Picture 4.7 Raising the mast.



Picture 4.8 Raising into place.

4.5 Rigging the spinnaker halyard.

When the spinnaker halyard is pulled it will hoist the spinnaker but also pull the bowsprit out too. However, the bowsprit outhaul block runs under the spinnaker chute so it is very difficult to get too. For this reason your Vision has been built with a rope already tied through the block to make it easy for you.

1. Pull on the rope mentioned above, the bowsprit will go out into the launched position. You should now be able to see the bowsprit outhaul block (see picture 4.9).
2. Take the loose end of the spinnaker halyard, from the block at the base of the mast, forward through the bowsprit outhaul block and then back to the spinnaker halyard cleat (see picture 4.10).
3. Thread the end of the halyard through the small wire fairlead in front of the cleat, through the cleat and through the hoist block (see picture 4.11).
4. The halyard then runs over the top of the centreboard and through the spinnaker drop block on the other side of the centreboard case. This time being thread through from back to front so the tail will then go up the spinnaker chute (see picture 4.12).



Picture 4.9 The bowsprit outhaul block.



Picture 4.10 Threading the spinnaker halyard.



Picture 4.11 The spinnaker halyard cleat.



Picture 4.12 The spinnaker downhaul block.

REMEMBER

When taking the mast down on your Vision, it is important to tie a piece of rope onto the bowsprit outhaul block so you can pull it back next time you rig the boat. The end of the spinnaker sheet is always to hand!

If you forget!

If you should forget to tie a rope to the bowsprit outhaul block and it disappears up under the chute, do not despair! Simply:

1. Peel off the black patch at the front of the spinnaker chute, this will reveal two blocks, one screwed to the boat, the other tied to a piece of rope.....this is the one you want.
2. Take the spinnaker sheet and thread it down through the hole in the spinnaker chute and feed it back along under the chute.
3. Tie the other end of the spinnaker sheet to the pole outhaul block.
4. Pull the spinnaker sheet through, pulling the pole outhaul block with it.
5. Replace the black patch.

4.6 Rigging the boom.

To complete this section, you will need:

- The boom.
- The Gnav (“vang” backwards, as it is working upside) bar.



GNAV Toggle Arrangement

595-487-E
Date: 050305

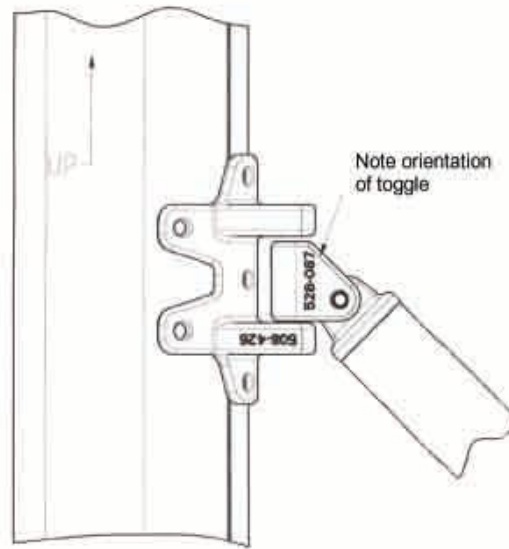

It is vital that the GNAV toggle is assembled as shown above.
Failure to do this will result in damage to the Strut Assembly

1. Connect the gnav bar to the slider at the front end of the boom (see picture 4.13). Note: the slider fitted may look different to the picture but it still works in the same way.
2. Connect the front of the boom to the gooseneck on the mast (see picture 4.14).
3. Connect the upper end of the gnav bar to the bracket on the mast above the gooseneck (see picture 4.15).
4. Feed the gnav control line down through the swivel block and cleat below the boom and tie a stopper knot in the end of the rope (see picture 4.16).



Picture 4.13 Connecting the gnav to the boom.



Picture 4.14 Connecting the gnav to the mast



Picture 4.15 The gnav control line.



Picture 4.16 The gnav fully rigged.

4.7 Hoisting the jib.

To complete this section, you will require:

- The jib.
- The jib sheets.
- The top furling unit and shackle.

- The long rigging link.
1. Unroll the jib and connect the tack (lower forward corner) to the shackle attached to the lower furling unit in the tack bar (see picture 4.17).
 2. Attach the top furling unit to the wire end of the jib halyard, using the shackle provided (see picture 4.18).
 3. Attach the head (top corner) of the jib to the top furling unit (see picture 4.19).
 4. At the base of the mast, pull the jib up using the halyard. When the halyard is pulled all the way up a wire loop will emerge.
 5. Hook the rig tension to this wire loop (see picture 4.20), then pull the rig tension on, ensuring it is in the cleat properly. You should pull enough tension into the rig so the shrouds feel firm when pulled on.



Picture 4.17 The tack of the jib



Picture 4.18 The top furling unit.



Picture 4.19 The head of the jib attached.



Picture 4.20 Connecting the rig tension.

1. Find the middle of the jib sheet and tie a knot just to one side.
2. Pass one end through the rigging link and pull through until the knot.
3. Tie a knot on the other side (see picture 4.21).

4. Take one end either side of the boat and thread it firstly through the fairlead and then through the jib cleat. You can either tie a figure 8 stopper knot in each sheet or tie the two ends together.



Picture 4.21 Jib sheets.

4.8 The rudder.

To complete this section, you will require:

- The rudder.
 - The rudder stock.
 - The rudder downhaul and block.
- 1) Undo the plastic wing nut on the rudder stock and remove the bolt.
 - 2) Slide the rudder into the stock making sure to feed the rope over the small roller fitted in the stock, and out under the tiller.
 - 3) Line up the hole in the rudder with the hole in the rudder stock.
 - 4) Push the bolt through the stock and rudder, making sure to line up the head of the bolt with the recess in the plastic washer. Also that the little lugs on the plastic washer line up with the holes in the stock. *It may need a little tap to get it through!*
 - 5) Refit the plastic wing nut and tighten. The nut should be tight enough to stop the rudder slopping about in the stock, but not tight enough as to make it hard to rotate the rudder.
 - 6) Tie the rudder downhaul block onto the rope that you threaded into the stock (see picture 4.22).

- 7) Take the rudder downhaul rope and tie one end to the cleat at the front end of the tiller.
- 8) Thread the other end through the rudder downhaul block and then back through the cleat (see picture 4.23).
- 9) Tie a nice stopper knot in the end.



Picture 4.22 The rudder fitted in the stock.



Picture 4.23 The rudder downhaul fitted.

4.9 Hoisting the mainsail.

To complete this section, you will need:

- The mainsail.
- The mainsheet.

1. Tie one end of the mainsheet through the middle of the forward block in the middle of the boat using a bowline (see picture 4.24).
2. Then take the other end up to the forward block on the boom, passing it through from back to front (see picture 4.25).
3. Run the mainsheet back down to the forward block in the middle of the boat, this time passing it from front to back.
4. Take the mainsheet up to the aft block on the boom, passing it through from front to back.
5. Finally, thread the mainsheet through the aft block in the middle of the boat and through the cleat. Tie a figure 8 stopper knot (see picture 4.26).



Picture 4.24



Picture 4.25



Picture 4.26

1. Unroll the mainsail.
2. Tie the end of the main halyard that comes down the mast from the bullseye (not from the cleat) to the top of the mainsail (see picture 4.27).



Picture 4.27 Tying the main halyard.

1. Put the top of the sail into the opening in the mast track, just above the gooseneck mast collar.
2. Holding the sail in line with the mast, pull on the other end of the main halyard.
3. Pull the sail up to the top of the mast. You will need to keep the sail in line with the mast to make pulling it up easier, especially where the batten pockets are.
4. With the sail almost to the top, slide the mainsail clew slug into the track on the top of the boom (see picture 4.28).
5. Pass the end of the outhaul rope through the corner of the sail and clip it on the end of the boom (see picture 4.29)
6. Ensure that the main halyard rope is in the cleat and pull the sail to the top. Pull on the bottom corner of the sail to check it is properly cleated.
7. Tidy the main halyard and stow it in the bag next to the mast.



Picture 4.28 Mainsail slug.



Picture 4.29 Outhaul.

- 1) The downhaul is already tied to the mast, so all you need to do is pass the end of the rope through the bottom eyelet in the mainsail and then down through the cleat on the side of the mast (see picture 4.30).



Picture 4.30 The downhaul.

4.10 Rigging the spinnaker.

To complete this section, you will need:

- 1 x Vision spinnaker.
- 1 x spinnaker sheet.

HINT

Always remember to tie a piece of rope to the bowsprit outhaul block when fully de-rigging your RS Vision!

- 1) Unpack the spinnaker.
- 2) Tie the tack of the spinnaker to the 'tack line' that emerges from the end of the bowsprit (see picture 4.31). The knot that is already in the tack line needs to be left in place as it determines how far the bowsprit comes out.
- 3) Tie the end of the halyard to the head of the sail (see picture 4.32).
- 4) Take the spinnaker downhaul line (the other end of the halyard), which is rigged up the chute and with the spinnaker on the starboard (right) side of the boat pass the end through the ring on the sail from bottom of sail to top of sail direction (see picture 4.33).
- 5) Run the downhaul line up the sail and tie it off on the upper patch (onto the cross of webbing) (see picture 4.34).



Picture 4.31 The tack of the spinnaker.



Picture 4.32 The head of the spinnaker.



Picture 4.33 Lower downhaul patch.



Picture 4.34 Upper downhaul patch.

- 6) Find the middle of the spinnaker sheet and double it over to form a loop.
- 7) Pass this loop through the eyelet at the clew of the sail.
- 8) Pass the rest of the sheet through the loop and pull it tight (see picture 4.35).
- 9) Still with the spinnaker on the starboard side, thread one end of the spinnaker sheet through the block by the shroud point on the starboard side, in the direction of the arrow (see picture 4.36).
- 10) Take the other end of the spinnaker sheet and pass it around the forestay and into the block on the other side. Tie the two ends together.



Picture 4.35 Tying the spinnaker sheets.



Picture 4.36 The spinnaker sheet block

- 11) Pull the spinnaker from one side to the other, as if you were gybing, to see if anything is twisted.
- 12) Finally, pull the spinnaker down into the chute.

4.11 Completion.

Now you are almost ready to go Vision sailing. All that is left to do is:

- Fit the rudder to the back of the boat.
 - Tidy the halyards away.
- 1) To fit the rudder, simply line up the pins with the fitting on the back of the boat and push down until the retaining clip 'clicks' into place. The rudder may be difficult to get on at first but all it will need is a simple waggle from side to side whilst pushing down.
 - 2) To remove the rudder, simply push the retaining clip in and pull up on the stock.
 - 3) Coil the main and jib halyards neatly and stow them under the foredeck where there is a small bag on the starboard side.

Now you are ready to go sailing in your RS Vision!



5. SAILING HINTS

5.1 Introduction.

The RS Vision is a very rewarding boat to sail, and to fully appreciate its handling you should be comfortable with the basic techniques of sailing small boats. If you lack confidence or feel a refresher is in order, then there are many fully recognised sailing schools which use the RS Vision.

The following are simply hints to aid your enjoyment of your new boat and should in no way be considered a replacement for a recognised course in dinghy sailing. Choose a fairly quiet day with a steady wind for your first outing to build your confidence and familiarise yourself with your new boat.

5.2 Launching.

With the sails fully hoisted and the rudder attached to the transom, the boat should be wheeled into the water, keeping it head to wind as far as possible. If you have a crew, he or she can hold the boat head to wind whilst the trolley is stowed ashore.

5.3 Leaving the beach.

The easiest way to get going is for the helm to hop aboard while the crew holds the boat. The helm should put a little centreboard down, and move back to his normal position and pull gently on the rudder downhaul to lower some rudder blade. He then may instruct the crew to push the bow off the wind and climb in. The crew will then lower the centreboard as depth allows.

As soon as you are deep enough, make sure you lower the rudder blade fully by pulling the downhaul hard. You know it is fully down if you feel a gentle

"thud" as the front face of the blade hits the front face of the stock. Cleat the downhaul and tidy it by winding it around the tiller, pull the sails in and you are away!

HINT

If you are using the jib, then pulling this sail in first will ensure the bow continues to swing away from the wind.

For best affect you should ensure that you and your crew position yourselves to effect the best trim (fore and aft), and heel (sideways). The crew should always be on or in front of the raised seat section, and the helm up close to it. The boat should always be sailed as upright as possible.

HINT

As a general rule sit further forward in lighter winds and further aft in stronger breezes.

5.4 Sailing close-hauled and tacking.

When sailing as close as possible to the wind, it is important to get the boom close to the centreline. The gnav (strut kicker) should also be firmly tensioned for upwind work. Either do this before leaving the shore or by quickly luffing head to wind.

The jib should be sheeted fairly firmly upwind – tighter in the breeze and less so in the light. Sail to the jib tell-tails, keeping the leeward one streaming and the windward (nearest) one either streaming or lifting upwards.

You should hold the tiller extension across your body – with a knuckle upwards grip, and you can then use one or two fingers as a temporary cleat when adjusting the mainsheet.

As you tack, let the boat start to roll towards you before you cross the boat, and push the extension across in front of you, turning round forwards, and sitting down again with the extension round behind your back. Swap hands when you are settled, making use of the mainsheet cleat.

If the boat slows right down and feels lifeless when close-hauled, as a general rule it pays to ease both sheets and bear off away from the wind for a while to get the boat going again.

5.5 Downwind and gybing.

When sailing downwind both sails should be eased as far as possible, with the same rules applying to the tell-tails.

When gybing you pull the tiller towards you, and again as you cross the boat you push the extension across in front of you. The boom will often not want to come across until you are well through the gybe so it often pays to give the mainsheet a tweak to encourage the boom over at the moment you want it to come! Swap hands after you are settled on the new gybe.

5.6 Using the spinnaker.

If you are inexperienced in using spinnaker then chose a fairly quiet day for you first excursion with it. It will nearly double your sail area, and should be treated with a healthy degree of respect!

For your first hoist you should be sailing downwind on a broad reach, with the wind on your quarter. Your crew should sit in the centre astride the centreboard case, and hoist the spinnaker from the right hand halyard block (see picture 5.1).



Picture 5.1 Hoisting the spinnaker.

The halyard pulls the pole out at the same time, and so as the halyard comes to a stop when hoisted all is ready to go. The crew should now pull gently on the sheet, whilst the boat is luffed up gently and the spinnaker will soon fill.

Spinnakers may be effectively used from a close reach to a broad reach, and thus to get downwind one should become adept at gybing. Tacking is not possible with the kite set. For best affect the sheet should always be eased as far as possible, so that the luff is just on the point of curling.

Gybing with the spinnaker is fairly straightforward: Think of it exactly as a big jib, and it should be pulled across as the main comes across. As soon as it has been pulled in and filled with wind it should again be immediately eased for maximum efficiency and speed.

Dropping the spinnaker is the reverse of the hoist: The boat should be borne off to a broad reach, and the slack in the downhaul, pulled in from the left hand halyard block, taken up (see picture 5.2). As it goes tight the halyard should be popped out of the cleat and the spinnaker then pulled sharply into the chute. Dropping the spinnaker on tighter reaches is harder, requiring more effort on the downhaul (the end of the halyard that pulls the spinnaker down).



Picture 5.2 Dropping the spinnaker.

HINT

The spinnaker can “bunch up” when entering the chute, and this can be minimised by keeping some restriction on the sheet and thus stopping the clew getting sucked in with the main body of the spinnaker.

When the spinnaker is fully lowered it is always worth tidying the sheets and halyard to keep the cockpit area sorted.

5.7 Reefing.

Reefing is an effective and essential way to continue sailing in winds that would otherwise keep the less experienced or younger sailors ashore.

Reefing the mainsail is best done by both the helm and crew as a team. Work on the starboard side of the sail. With both the tack and clew (bottom corners) of the sail detached from the boom and mast, the sail should be rolled around itself from the base upwards. Roll fairly tightly and then when the zips come around to meet each other, zip up the roll, to keep it tidy and confined (see picture 5.3). The new slug slider may then be attached to the boom, and the sail re-hoisted.



Picture 5.3 Reefing the main sail.

HINT

The jib is very effective strong wind sail area because it is low down and maintains a balanced helm. So slab reef before you loose the jib – it's more fun for the crew anyway!

Strong wind sailing can be the best fun of all, so get familiar with the reefing systems and get back out there!

6. MAINTENANCE

6.1 Boat Care.

The RS Vision is made using Comptec PE3, a three layer polyethelene construction. This is stiff and light, but will dent if subjected to point loading. The boat should be supported ashore on a recognised RS trolley, as the hull may distort if not supported properly.

Obviously in dealing with a marine environment, equipment gets wet, which in itself is not a problem. The problem starts when moisture is trapped for any length of time. The key, therefore, is to store the boat properly ashore.

Keep your dinghy drained and well ventilated.

- Ensure the boat is stored with bow raised to allow water to drain away.
- If leaving the under cover on the boat, ensure that the transom is open for drainage and that there is a hole below the centreboard slot to allow water to drain.

Wash with fresh water.

Fresh water evaporates far more quickly than salt water; so if your dinghy has been sailed in salt water wash it off thoroughly. The fittings will also work better if regularly washed.

Hull damage falls into three categories:

- **SERIOUS** – large hole, split, crack or worse. Don't be too distressed! Get the remnants back to RS Racing – most problems can be repaired.
- **MEDIUM** – small hole or split. If this occurs during an event, sailing can often be continued as long as leaking can be prevented by drying the area and applying strong adhesive tape. **CAUTION** – if the damage is



close to a heavily loaded point then a close examination should be made to ensure the surrounding area will accept the loads. Get the damage professionally repaired as soon as possible.

- **SMALL** – dents, scratching. This type of damage is not boat threatening.

Comptec PE3 cannot be repaired in the same way as fibre glass. Some scratching can be removed by RS Racing staff, but dents cannot. Therefore we suggest you treat your boat with as much care as you would a fibre-glass one. More serious repairs can also be carried out by RS Racing staff.

The joy of owning a Vision is that it is very hard wearing and any dents and scratches it receives will not do the structure of the boat any harm and you will still be able to sail it, unlike fibre-glass boats.

6.2 Foil Care.

The foils too are moulded plastic, this time injection moulded. They are very strong and hard wearing, but they will get damaged if run aground hard. A damaged foil can still be used, however, due to the nature of its construction.

If you are going to trail your boat lots, you may wish to invest in some RS Racing padded rudder bags. These will protect your Vision from any damage caused by the foils.

6.3 Spar Care.

The mast, boom and bowsprit are aluminium. Wash with fresh water as often as possible, both inside and out. Check all the riveted fittings on a regular basis for any signs of corrosion or wear.



6.4 Sail Care.

The main should be rolled and stored dry, out of direct sunlight. Dry the spinnaker, fold it and store it in its bag.

When using a new sail for the first time, try to avoid extreme conditions because high loads on new sailcloth can diminish the racing life of the sail.

If your sail is stained in any way, try to remove it using normal detergent and warm water. **DO NOT** attempt to launder the sail yourself.

Repairs should be temporarily made using self-adhesive Dacron, Mylar or spinnaker repair tape (depending on sail type). The sail should be returned to a sail maker for a professional repair. Check for wear and tear, especially around the batten pockets and boltrope, on a regular basis.



7. WARRANTY

1. This warranty is given in addition to all rights given by statute or otherwise.
2. LDC Racing Sailboats warrants all boats and component parts manufactured by it to be free from defects in materials and workmanship under normal use and circumstances, and the exercise of prudent seamanship, for a period of twelve (12) months from the date of commissioning by the original owner. The owner must exercise routine maintenance and care.
3. This warranty does not apply to defects in surface coatings caused by weathering or normal use and wear.
4. This warranty does not apply if the boat has been altered, modified, or repaired without prior written approval of LDC Racing Sailboats. Any changes to the hull structure, deck structure, rig or foils without the written approval of LDC Racing Sailboats will void this warranty.
5. The use of the boat for commercial purposes shall void this warranty.
6. Warranty claims for materials or equipment not manufactured by LDC Racing Sailboats can be made directly to the relevant manufacturer. LDC Racing Sailboats warrants that these parts were installed correctly and according to the instructions provided by the manufacturer.
7. Warranty claims shall be made to LDC Racing Sailboats as soon as practicable and, in any event, within 28 days upon discovery of a defect. No repairs under warranty are to be undertaken without written approval of LDC Racing Sailboats.
8. Upon approval of a warranty claim, LDC Racing Sailboats may, at its expense, repair or replace the component. In all cases, the replacement will be equal in value to the original component.
9. Due to the continuing evolution of the marine market, LDC Racing Sailboats reserves the right to change the design, material, or construction of its products without incurring any obligation to incorporate such changes in products already built or in use.