

RS Zest: De-rigging at Renton Sailing Center

Single page Summary Checklist:

- Remove sail pressure:
 - [Luff jib] and luff mainsail.
 - Ease outhaul and vang
- [Drop jib. Pull jib halyard all the way off]
- Detach outhaul and remove boom from gooseneck
- Detach vang from mast and furl mainsail around the mast
- Put the rudder in the kicked-up position.
- Raise centerboard
- [Bring the boat onto the dock.](#)
- Remove rudder.
- Remove jib
- Unstep mast. Store vertically on rack.
- Tie centerboard in upright position
- Wash boat
- Place boat on rack. Attach security cable.

RS Zest: De-rigging at Renton Sailing Center



Dock at the desired de-rigging location, while pointed as closely as possible into the wind.

Step 1: Remove sail pressure:

- Crew:
 - luff the jib and begin lowering the jib halyard. Pull the halyard all the way off the mast. Keep the jib inside the boat. Keep the halyard, sheets, and tack line attached to the jib.
 - Ease Outhaul.
 - Ease Vang

- Helms-person:
 - Detach hook from mainsail clew.
- Crew:
 - Before the boom aft end drops into the boat, remove the boom from the gooseneck!¹
 - Detach the vang from the mast
 - Roll the mast counterclockwise (as viewed from above) to begin furling the mainsail around it. *Note that the jib halyard and vang must be removed by this point in time.*
- Helms-Person:
 - Ease clew and crew rolls for a smooth furl and to avoid sail flapping. *Note that starboard side of mainsail needs to be exposed when furled in order to use the white webbing and white plastic hook near the clew to tie down the furl.*
 - Put the rudder in the kicked-up position.
 - Two block main sheet, flake and store on thwart bench.

¹ At this point, begin working from mid-ship, so as to avoid the clew flapping around the aft part of the boat.



- Crew
 - Raise centerboard

Step 2: Bring the boat onto the dock. *Note: with the mainsheet still attached, the boom will not be accidentally lost overboard.*

Step 3: Perform the following unrigging on the dock:

- Remove the rudder. Reattach the hitch pin to the top pintel. Store in East Dock Box
- Jib: untie the jib tack and pull the jib sheets through the cleats. Leave sheets, tack line and halyard attached to the jib and flaked. Flake and store jib in sail bag and store in east dockbox.
- Open the mast-gate, pull the mast slightly up then carefully ease aft. Re-attach the safety pin in its hole in the mast step.

- Cover furlled main with UV sock and lash vertically to rack.
- tie centerboard in up position with bow dock line to centerboard rope handle using two half-hitches on a bight to keep centerboard from slipping down on rack.



Step 4: Wash away footprints and bird droppings with soap and water.

Step 5: Use 2 or more people on the dock to lift the boat and place it on the rack, bow pointed towards park. Note: the boat on the top of the rack will require additional hands.

Step 6: Lash the masts to the horizontal rail using the Square Lashing and Clove hitch as shown below:

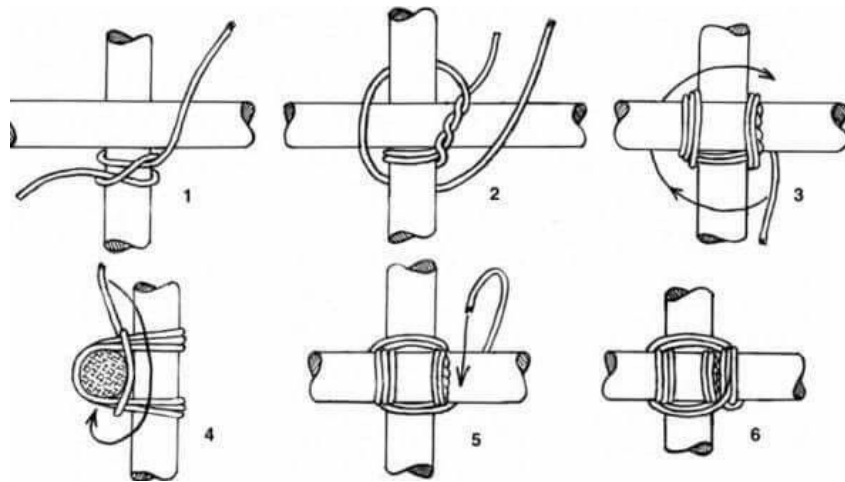

Step 7: Lock security cable through hole in center of transom and smaller cable through the vang padeye near base of mast.

